

KELVINOX

Kelvinox®

Dilution refrigerators to suit all applications



KELVINOX

Which **Kelvinox** is right for you?

When choosing a **Kelvinox** system, there are technical parameters that you need to consider in order to achieve the desired instrumentation for your research

The **Kelvinox** range was first introduced in 1988, designed for seamless integration into magnetic and cryogenic environments. This high-performance range has since established itself as an industry leader thanks to a combination of build quality, value and a high level of automation. The **Kelvinox** range has been continually updated and enhanced,

with innovations such as the **Kelvinox**IGH Intelligent Gas Handling system and the **Kelvinox**MX multiple experiment range which provides new levels of flexibility and modularity.

Oxford Instruments has used its expertise in cryogenics to ensure that our systems offer unrivalled versatility and ease-of-use to the research community.

There are four products to choose from in the **Kelvinox** family:

System Selection

Base temperature requirement below 25 mK

- Multi-experiment or multi-user experimental access



KelvinoxMX

- High access for complex experimental services



Kelvinox400HA

- Neutron or x-ray scattering experiments
- No liquid helium in horizontal sample path

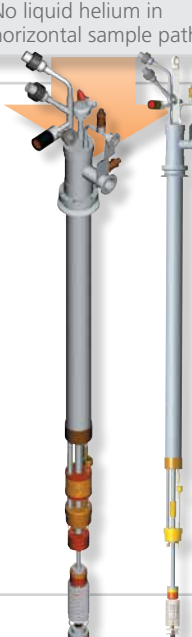

KelvinoxVT / JT

- Quick turnaround time and multi-user access
- Sample in liquid

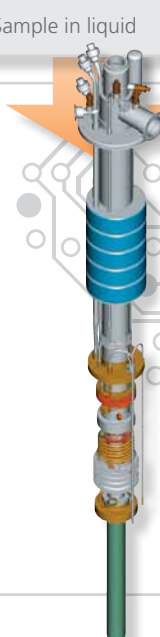

KelvinoxTLM

KELVINOX

Base temperature

The base temperature is measured in vacuum at the base of the mixing chamber (except for our sample-in-liquid systems).

Cooling power

Cooling powers are quoted at 100 mK to allow comparison between the thermodynamic performances of different dilution refrigerators. The cooling power for **Kelvinox** systems ranges from 15 μ W to \geq 400 μ W at 100 mK.

Sample environment

In the case of the **KelvinoxMX**, **KelvinoxVT / JT** and **Kelvinox400HA**, the sample is mounted in vacuum directly onto the mixing chamber and cooled by conduction. In the **KelvinoxTLM**, the sample is directly immersed in liquid in the mixing chamber and is cooled by conduction through the liquid.

Patented technology

Oxford Instruments holds a number of key patents in dilution refrigerator design. These patents cover the **KelvinoxTLM** integral probe and the fast sample change capability, advanced FemtoPower™ thermometry and the modularity and flexibility of the **KelvinoxMX** range.

Designed for key applications

The extensive range of electrical and sample access options allow applications such as fractional quantum Hall effect, soft X-ray detection or quantum computing studies. The versatility of sample environments, whether in liquid or vacuum, enables techniques requiring large heat load dissipation, such as microwave excitation or solid state NMR, to be performed under the optimum thermodynamic conditions. Our products are designed to suit the most demanding applications.

Research Areas	Applications	Experimental Techniques
Semiconductors	Quantum Hall effect Quantum dots Single electron tunneling Quantum computing	Magneto-resistance Hall effect RF transport High frequency conductivity
Solid state physics	Heavy fermion systems Metal insulator transition Spin glass Mesoscopic systems Giant magnetic resistance	Specific heat De Haas-van Alphen oscillations Solid state NMR Electrical resistivity Magneto-resistance Neutron scattering
Superconductivity	Low T_c superconductors Quantum computing Josephson junctions Flux vortices Quantum initial phenomena	Electrical resistivity Scanning spectroscopy (STM/AFM) Squids AC susceptibility
Astrophysics & cosmology	Low temperature detectors Superconducting tunnel junctions Ge bolometers	Electrothermal measurements Voltage biased measurements Low energy photon detection
Metrology	Quantum hall effect Voltage standards Current standards	Magneto-resistance DC & AC low frequency transport and magnetic measurements Single electron tunneling

KelvinoxMX

Modular design

The **KelvinoxMX** uniquely separates the cooling platform from the experimental services. This offers:

- Flexibility to change experimental configurations and thermodynamic performances if needed
- Multiple users to carry out different configured experiments, with minimum downtime
- Access to different applications by selecting the appropriate experimental insert
- Simple diagnostics: experimental wiring and set-up can be easily tested
- Full automation: all inserts are supplied with a gas handling system (**KelvinoxIGH**) enabling automation of the insert cool down

Components

The **KelvinoxMX** is made up from three main components:

- **Primary insert:** provides a 50 mm line-of-sight access into which a range of interchangeable experimental inserts can be fitted. 1.5 K cooling is provided by continuous flow of 4He through the innovative stretched 1 K condenser design which minimises microphonic noise generation. Rapid experimental turnaround times are enabled by a sliding seal permitting safe removal and replacement of the dilution refrigerator, while minimising helium loss.
- **Dilution unit:** there are two choices of dilution unit (see table).
- **Experimental insert**

Basic: fitted with a 6 mm line-of-sight access to the inner vacuum can (IVC).

High Frequency: equipped with semi-rigid and flexible co-axial lines. Ideal for high frequency applications (<20 GHz). It is also fitted with a 24-wire loom to the mixing chamber position.

Rotator: this insert is fitted with similar services to the High Frequency model. A rotating mechanism, Swedish rotator (manual or automated) is also supplied.

Versatile: this is an ideal platform to customise your own experiment. Experimental access is provided by a 15 mm diameter line of sight port to the mixing chamber and 3 x 8 mm diameter line of sight ports to the IVC. These are terminated at room temperature by NW25/16 flanges.

Dipper insert: this adapts the versatile insert and allows it to be cooled independently of a **KelvinoxMX** by immersing it directly in liquid helium either in a transport dewar or in an **Integra™** system dewar.

The **KelvinoxMX** is covered by US Patent No. 6758059.



Top to bottom: Versatile, high frequency and basic experimental inserts

Model	Cooling power at 100 mK	Base Temperature
MX100	100 μ W	15 mK
MX400	400 μ W	7 mK

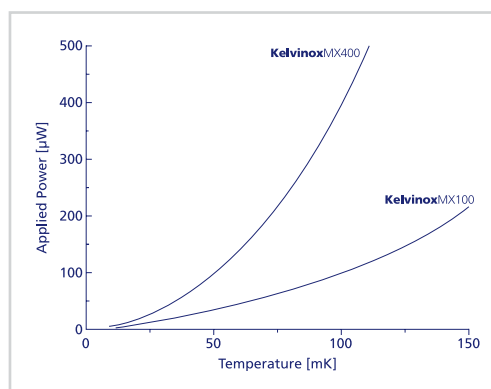

Cooling power plotted as a function of base temperature for **KelvinoxMX** models

Kelvinox400HA

High access

- Ideal for applications requiring high cooling power and enhanced experimental access such as quantum computing
- Achieves more than 400 μ W of cooling power ideal for demanding experiments with high heat dissipation such as microwave cavity losses
- Less than 7 mK stable base temperature: ideal for low temperature demagnetisation experiments
- Additional line-of-sight access ports enabling a range of services to the IVC and sample space, for the most demanding applications

Cryofree® options:

Oxford Instruments also offers the most extensive range of cryofree dilution refrigerators. Contact your local sales representative to get more information.

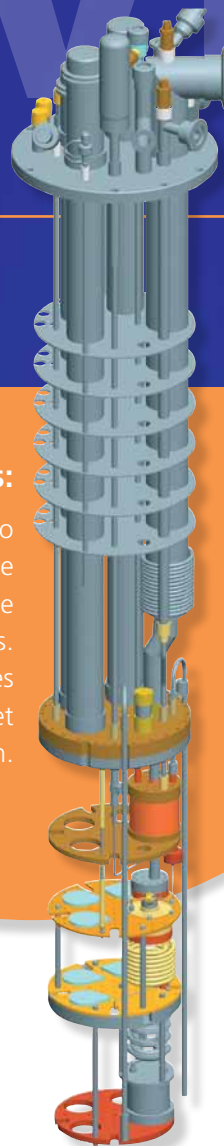

Improved experimental access

Inserts are provided with a wide range of access ports:

- Line-of-sight to mixing chamber: 3 x 38 mm line of sight access from room temperature to the mixing chamber through cutouts in the 1 K and still flanges inside the IVC. These are ideal for drive rods, mechanisms such as Swedish rotators or installation of waveguide or semi-rigid co-axial cables
- Spare ports - 4 x 12.7 mm diameter from the 4 K helium bath to the IVC. These have de-mountable soldered caps. Matching ports are ideal for a 4 K thermal anchoring of low temperature electronics

IntegraAC Cryostat

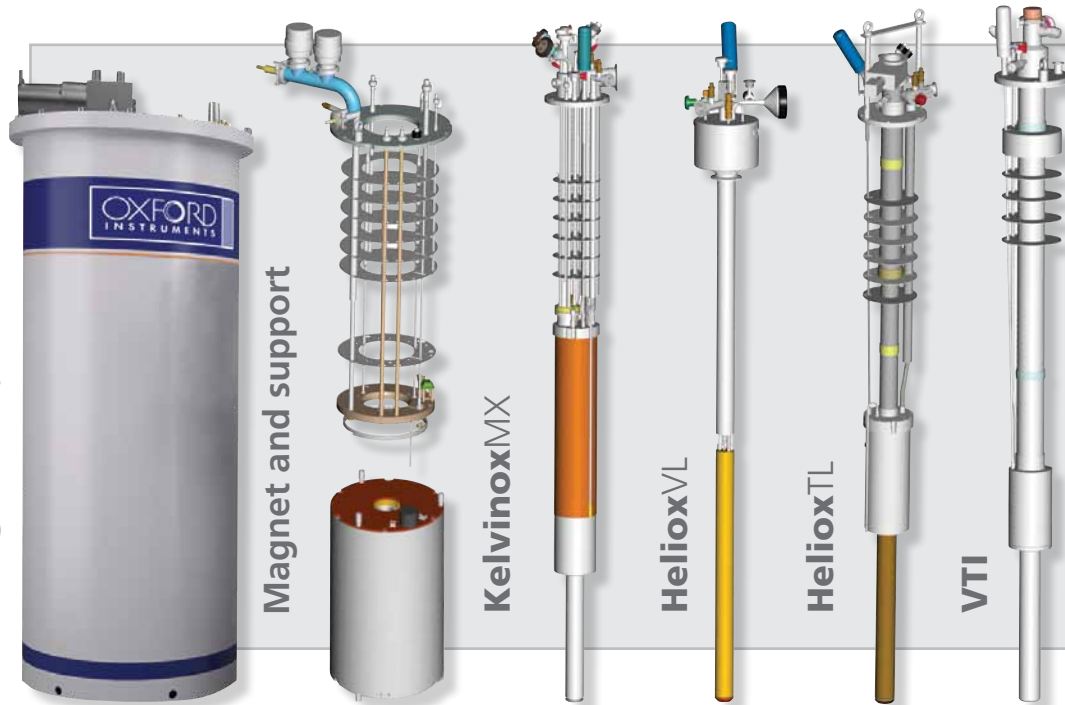

Combined low temperature

The **KelvinoxMX**, **Kelvinox400H** integrated into complete cryomagnets 8 T at 4.2 K to 21 T at 2.2 K, field homogeneity spherical volume and 52 mm bore.

Solution to helium rising cost

All **Kelvinox** inserts are compatible with the helium cryostat. This product has been designed to reduce consumption of liquid helium by recycling the helium system, which would otherwise be vented. This reduces the frequency of helium refills. Cryogen is only used when in stand by mode, leading to

KelvinoxVT KelvinoxJT

Sample in vacuum, no 1K pot



KelvinoxVT

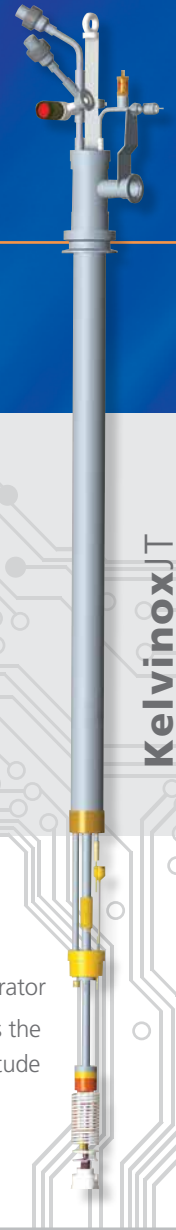

KelvinoxJT

- Ideal for neutron or X-ray scattering applications: no liquid in the horizontal sample path; no 1K pot
- Wide temperature range: the temperature can be controlled between 25 mK and 300 K by appropriate use of exchange gas
- Quick cooldown time: these compact inserts can be cooled down to base temperature in around three hours from loading

KelvinoxVT

- Operates in the cold environment of a 50 mm variable temperature insert (VTI)

To find out more about the **Kelvinox** range of products, including applications and modes of operation, visit www.oxfordinstruments.com

KelvinoxJT

- No need for VTI, requires 4 K bath only!
- Can use helium bath or Pulse tube Refrigerator
- Replaces any **HelioxVL** insert and extends the temperature range by one order of magnitude
- Dry low power gas handling
- J-T ³He recondensing stage

and magnetic field sample environment

A, **KelvinoxVT** and **KelvinoxTLM** can be used in magnetic systems. Magnet options provide fields from 0 to 10 T with homogeneity of 0.1% over a 10 mm diameter

...sts:
... with the **Integra™AC** recondensing liquid nitrogen system has been developed to significantly reduce the amount of recondensing helium gas evaporated within the cryostat. This decreases the heat load on the cryostat. This means that magnetic systems can be kept cold continuously, even during long experiments. This gives you greater freedom to schedule experimental time.

Automation and control of your dilution refrigerator using the KelvinoxIGH – Intelligent Gas Handling system

The **KelvinoxIGH** is a fully automated system which enables complete operation of a dilution refrigerator using sophisticated software and virtual instrument drivers for National Instruments' LabVIEW™.

The virtual instrument drivers may be incorporated in higher level programs to provide fully automated experiments. This includes:

- Filling and controlling the 1 K pot
- Mixture condensation
- Mixture circulation
- Automated cooling to base temperature from 4 K
- Control to a set temperature
- Control and monitoring of valves, pressures, temperatures and heaters
- Single shot operation
- Leak test mode

The **KelvinoxIGH** is covered by US Patent No. 6158887.

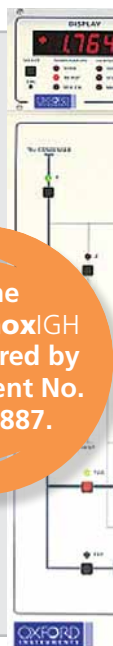

Kelvinox^{TLM}

Top loading

The Kelvinox^{TLM} is covered by US Patent No. 6202439.

- High performance with a base temperature of less than 15 mK and cooling power of more than 400 μ W
- Top loading of the sample directly into the 3He/4He mixing chamber ensures good sample thermalisation, high stability of the thermal environment and guarantee of operation in high magnetic field
- Multi-service, multi-user access: unique design which can be used with a range of sample probes such as a Swedish rotator or high frequency co-axial lines
- Quick and easy sample change: no need to remove the mixture during sample change, giving quicker experiment turnaround times and reducing the risk of leaks
- Non metallic sample environment – ideal for experiments such as solid state NMR when removing metallic material surrounding the pickup coil resonant circuit is key to accurate measurements. Typically, field sweeps of up to 2 T / min leave the temperature of the mixture unaffected

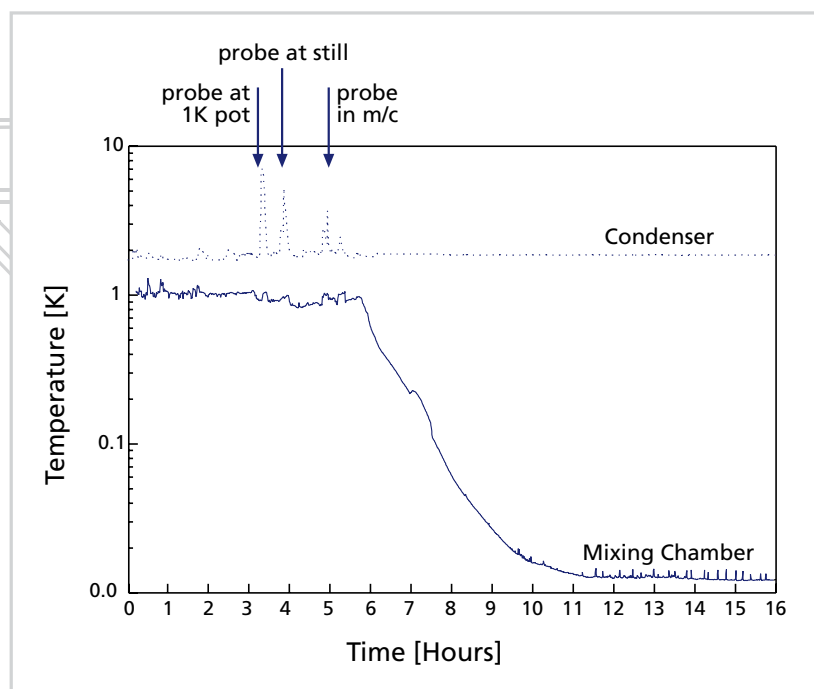
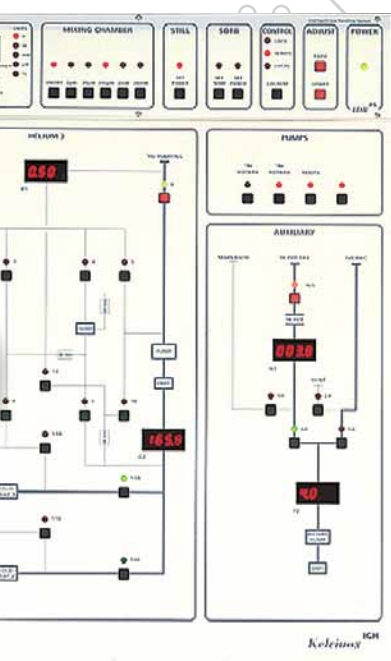

Effect of lowering a probe into the mixing chamber. The temperature on the condensing stage is shown to rise as the probe is inserted and an additional heat load is created at the 1 K pot. However the mixture remains at constant temperature throughout the loading process minimising the cooldown and re-circulation interval. Once fully loaded and in position the sample cools to base temperature in about 6 hours.



KELVINOX

iService[®]

A global reach

By choosing Oxford Instruments as the supplier of your next dilution refrigerator system, not only are you getting a reliable product but also access to a service support team.

This includes:

- Our team of more than ten expert service engineers have more than 100 years of experience, based on the successful installation of hundreds of magnet and low temperature systems
- Five people dedicated to helpdesk
- Bespoke Cryospares service

ServiceWise extended warranty

Oxford Instruments offers a standard 12-month warranty on all products. You can also upgrade this cover and purchase extended warranty. Warranty covers parts, labour, return from the factory and third-party items and on-site service if required. We can also loan control electronics and pumps, subject to availability.



visit www.oxford-instruments.com for more information

Oxford Instruments NanoScience

For more information please email:
nanoscience@oxinst.com

UK

Abingdon, Oxfordshire
Tel: +44 1865 393 200

China

Shanghai
Tel: +86 21 6490 8280

Germany

Wiesbaden
Tel: +49 6122 937 171

Italy

Pieve Emanuele, Milan
Tel: +39 335 7378794

Japan

Tokyo
Tel: +81 3 5245 3261

USA

Concord, MA
Tel: +1 978 369 9933

www.oxford-instruments.com

This publication is the copyright of Oxford Instruments plc and provides outline information only, which (unless agreed by the company in writing) may not be used, applied or reproduced for any purpose or form part of any order or contract or regarded as the representation relating to the products or services concerned. Oxford Instruments' policy is one of continued improvement. The company reserves the right to alter, without notice the specification, design or conditions of supply of any product or service. Oxford Instruments acknowledges all trademarks and registrations. © Oxford Instruments plc, 2011. All rights reserved. Part no: OINS/KELVINOXOINS/2011/06



The Business of Science[®]