

# Kelvinox|GH Electronics

Revision 6

Nov 07

UMC0028

**Oxford Instruments NanoScience**

Tubney Woods, Abingdon,

Oxon, OX13 5QX, England

Tel: +44 (0)1865 393 200

Fax: +44 (0)1865 393 333

E-mail: [nanoscience@oxinst.com](mailto:nanoscience@oxinst.com)

[www.oxford-instruments.com](http://www.oxford-instruments.com)



## Contents

|       |  |    |
|-------|--|----|
| 1     | Warning .....                                  | 5  |
| 2     | Cautions .....                                 | 6  |
| 3     | Safety .....                                   | 7  |
| 3.1   | Protective Ground .....                        | 7  |
| 3.2   | Repair and Adjustment .....                    | 7  |
| 3.3   | Disposal and recycling .....                   | 7  |
| 4     | Introduction .....                             | 8  |
| 4.1   | Use of this Manual .....                       | 8  |
| 4.2   | Description of KelvinoxIGH .....               | 8  |
| 5     | Installation .....                             | 10 |
| 5.1   | Classification .....                           | 10 |
| 5.2   | Supply Connections .....                       | 10 |
| 5.2.1 | Electrical Safety .....                        | 10 |
| 5.3   | Environment .....                              | 11 |
| 5.4   | Handling and Storage Including Transport ..... | 11 |
| 5.5   | Maintenance .....                              | 11 |
| 5.6   | Cleaning .....                                 | 12 |
| 5.7   | Connections .....                              | 12 |
| 5.8   | Mounting Instruction .....                     | 12 |
| 5.9   | Sensor Connections .....                       | 13 |
| 5.10  | Dilution Unit Connections .....                | 14 |
| 5.11  | Cryostat Connections .....                     | 14 |
| 5.12  | RS232 Serial Data Line Connections .....       | 15 |
| 5.13  | The Oxford Instruments ISOBUS .....            | 16 |
| 5.14  | GPIB (IEEE-488) Connection (Optional) .....    | 16 |
| 5.15  | The GPIB to ISOBUS Gateway .....               | 17 |
| 5.16  | Auxiliary Port Connections .....               | 17 |
| 5.17  | Relay Box Connections .....                    | 18 |
| 6     | Local Operation .....                          | 19 |
| 6.1   | Front Panel Controls on IDR .....              | 19 |
| 6.2   | Mimic Panel Controls on KelvinoxIGH .....      | 22 |
| 7     | Remote Operation .....                         | 24 |
| 7.1   | Introduction .....                             | 24 |
| 7.2   | Communication Protocols .....                  | 24 |
| 7.3   | Commands and Responses .....                   | 25 |
| 7.4   | Numeric Parameters .....                       | 25 |
| 7.5   | Use with Oxford Instruments ISOBUS .....       | 26 |
| 7.6   | The GPIB Interface .....                       | 27 |
| 7.6.1 | Sending Commands via the GPIB .....            | 27 |
| 7.6.2 | Accepting Responses via the GPIB .....         | 28 |
| 7.6.3 | The Status Byte, Use of a Serial Poll .....    | 28 |
| 7.6.4 | Use of the Service Request Line .....          | 29 |
| 7.6.5 | Use of the Device Clear Function .....         | 29 |

|    |        |  |    |
|----|--------|--|----|
|    | 7.6.6  | Use of the Interface Clear (IFC) Function .....        | 29 |
|    | 7.6.7  | Non-Implemented Features of the GPIB .....             | 29 |
|    | 7.6.8  | Compatibility with IEEE-488.2.....                     | 29 |
|    | 7.6.9  | Use of the GPIB Interface as a GATEWAY to ISOBUS ..... | 30 |
|    | 7.6.10 | Writing a "Rugged" GPIB Control Program .....          | 30 |
| 8  |        | Command List .....                                     | 31 |
|    | 8.1    | Operating Commands .....                               | 31 |
|    | 8.2    | System Commands.....                                   | 35 |
| 9  |        | Calibration and Configuration .....                    | 37 |
|    | 9.1    | Temperature Sensor Calibration .....                   | 37 |
|    | 9.2    | Storing Calibration and Other Data.....                | 38 |
|    | 9.3    | Entering Test Mode.....                                | 38 |
|    | 9.4    | Pressure Gauge Calibration .....                       | 39 |
|    | 9.5    | Setting the GPIB Address .....                         | 39 |
| 10 |        | Servicing.....   | 41 |
|    | 10.1   | Circuit Description.....                               | 41 |
|    | 10.2   | Circuit Diagrams .....                                 | 42 |

**© Oxford Instruments NanoScience, 2007. All rights reserved.**

You may make hard copies of this manual for your organisation's internal use in connection with the system with which it was supplied, provided that the integrity of the manual is maintained and this copyright notice is reproduced. Other than as permitted above, you may not reproduce or transmit any part of this document, electronically or mechanically without the prior written permission of Oxford Instruments NanoScience.

Oxford Instruments' policy is one of continued improvement. The Company reserves the right to alter without notice the specification, design or conditions of supply of any of its products or services. Although every effort has been made to ensure that the information in this manual is accurate and up to date, errors may occur. Oxford Instruments NanoScience shall have no liability arising from the use of or reliance by any party on the contents of this manual and, to the fullest extent permitted by law, excludes all liability for loss or damages howsoever caused.

The Oxford Instruments Logo and Kelvinox are trademarks of Oxford Instruments plc or its subsidiaries. The use of our trademarks is strictly controlled and monitored and any unauthorised use is forbidden.

# **1 Warning.**

- 1. High Voltage Hazard. Isolate this equipment by switching off the external AC electrical supply, disconnecting and removing the external supply cable.**
- 2. The equipment does not have a front panel switch for turning the power on or off. It relies on the external mains switch. Access to this must not be restricted at any time. The external AC electrical supply cable must also remain accessible for disconnection of the equipment.**
- 3. Maintenance: Only qualified and authorised persons should carry out servicing and repair work on this equipment.**
- 4. High Voltage Hazard: High voltages are present inside this equipment. Isolate this equipment by switching off the external AC electrical supply, disconnecting and removing the external supply cable before any covers are removed.**
- 5. Heavy Load Hazard. Care must be taken when moving the unit. It must not be lifted by the small front handles. Always use appropriate lifting equipment which must be positioned under the unit.**
- 6. There are two separate mains voltage selectors, one on the IDR unit and the other on the IGH unit. The voltage selectors cover four AC voltage options 100 V, 115 V, 200 V and 230 V. Set both selectors to the same value nearest to the nominal local mains voltage.**
- 7. If the equipment is used in a manner not specified by the manufacturer, the protection provided by the equipment may be impaired.**
- 8. The equipment is not suitable for use with explosive or flammable gases. The equipment is not suitable for use in explosive, flammable or hazardous environments. The equipment is suitable for use with Helium3 and Helium4.**
- 9. The equipment consists of several solenoid valves, stepper motor driven valves and hoses. The user should not replace any of the valves or motors. In the case of a problem with a valve, motor or hose, the unit must be repaired by or returned to Oxford Instruments.**
- 10. The equipment does not provide protection against the ingress of water. The equipment should be positioned so that it will not be exposed to water ingress.**

## 2 Cautions

- 1 **ELECTROSTATIC HAZARD:** *This equipment contains Electrostatic Sensitive Devices (ESSD). ESSD protective procedures in accordance with BS CECC00015 Part 1 and American National Standard EIA-541-1988 must be applied when installing or maintaining this product. Refer to guidelines in the preliminary pages.*
2. **COOLING HAZARD.** *Internal components are air-cooled. Ensure the front lower ventilation space is not obstructed.*

### *Explanation of symbols used in the Instrument*



***Attention; please refer to the manual***



***Functional earth***

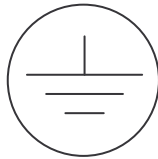

***Protective earth***

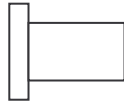

***OFF***



***ON***

## 3 Safety

The following general safety precautions must be observed during the operation, service and repair of this instrument.

### 3.1 Protective Ground

To prevent an electrical shock hazard, the instrument must be connected to an electrical ground. The ground wire (green/yellow) in the instrument power cable must be connected to the installation electrical ground system. Do not use extension cords without a protective earth conductor. Do not disconnect the protective ground inside or outside the instrument. Do not have external circuits connected to the instrument when its protective ground is disconnected.

### 3.2 Repair and Adjustment

**Under no circumstances is the user permitted to adjust or repair this unit while mains is connected.**

Ensure that the instrument is disconnected from the AC power supply (switching off the POWER switch is not sufficient) before the covers are removed or fuses are replaced, otherwise dangerous voltages are accessible. Capacitors inside the instrument and power connector filter, if fitted, may remain charged after removal of AC power. These should be discharged before starting work.

### 3.3 Disposal and recycling

Before disposing of this equipment, it is important to check with the appropriate local organisations to obtain advice on local rules and regulations about disposal and recycling.

You **must** contact Oxford Instruments NanoScience Customer Support (giving full product details) before any disposal begins.

## 4 Introduction

### 4.1 Use of this Manual

This manual provides technical information for the Oxford Instruments Intelligent Gas Handling System model KelvinoxIGH.

Normal operation of the Kelvinox Gas Handling system, either from its front panel, or via a computer, is described in the Kelvinox System manuals. This manual is intended to provide you with additional information to help you understand the working of the system and recalibrate the system, should you need to do so.

“ No adjustment or repair allowed by user while mains connected to the system in any case”.

During 1998, the Oxford Instruments FemtoPower input stage was introduced. This allows the mixing chamber temperature to be monitored by resistance thermometry, over the full working range of the Kelvinox. At the same time a temperature control facility was added allowing temperature control of the fridge based on this thermometer (before this time external thermometry and an external temperature controller were required). At a number of places in this manual, the changes associated with the introduction of FemtoPower are mentioned. It is easy to identify which version of the KelvinoxIGH you have. All versions fitted with FemtoPower, carry the words **Intelligent Gas Handling System with FemtoPower Thermometry** in the top right hand corner of the front panel.

### 4.2 Description of KelvinoxIGH

KelvinoxIGH covers the complete electronics package required to control the operation of a Kelvinox Dilution Refrigerator. It is made up of two main sections, mounted together in a single case.

The larger, lower section contains all the valves and gauges required to monitor and control the flow of gas in the  $^3\text{He}$  and  $^4\text{He}$  circuits. Its front panel consists of a Mimic diagram showing the gas circuits, with control buttons and status indicators associated with each of the valves and digital pressure displays associated with each of the gauges.

The upper section consists of the Intelligent Dilution Refrigerator Power Supply IDR<sup>PS</sup>. It provides power for the various heaters needed to operate the dilution refrigerator and includes the thermometry needed to monitor their operation. In addition it contains the computer interface and control logic needed operate the valves and gauges on the mimic panel.

For convenience in this manual, the abbreviation IGH will be used to refer to the lower section and the abbreviation IDR to refer to the upper section. When referring to the complete system, KelvinoxIGH will be used. It is possible to use IDR in stand alone applications to provide heater supplies and thermometry for a system using manual control valves. If you have such a system, you should ignore all references to IGH. It is not possible to use IGH on its own since all the control logic for the valves is contained within IDR.

IDR is a microprocessor based instrument and is controlled by an operating program contained in a programmable memory chip (EPROM). This program is referred to as the IGH firmware. The firmware is coded with a two part number (e.g. 1.01) where the first digit indicates a major version of the firmware and the second two digits cover minor revisions. At the time this manual was written, there have been three major versions of firmware.

- Version 1.xx supported a stepper motor driven valve for V12A.
- Version 2.xx supported a version of hardware where this motorised valve had been replaced with a proportional solenoid valve, providing a more rapid response.
- Version 3.xx retains the proportional solenoid valve but also supports the use of the FemtoPower input card.

Sensor calibration data and many of the KelvinoxIGH operating parameters are held in a non-volatile memory, which is retained when the KelvinoxIGH is switched off.

## 5 Installation

### 5.1 Classification

The IGH is Class1 Equipment.

The equipment is not suitable for use in the presence of a flammable anaesthetic mixture with air or with oxygen or with nitrous oxide.

### 5.2 Supply Connections



Before applying power to the instrument, ensure that the two voltage selectors on the IDR and IGH, are correctly set for the intended supply voltage. There are two separate mains voltage selectors, one on the rear panel of the IDR and other on the rear panel of the IGH. The selectors cover four voltage options 100 V, 115 V, 200 V and 230 V. Both selectors should be set to the same value nearest to the nominal local mains AC voltage.

The Maximum power input for the Equipment is 250 W.

If necessary, open the voltage selector panels using the slot provided, withdraw the voltage selector and replace it in the correct orientation for the intended voltage, then close the voltage selector panel.

Check that the correct fuses are fitted.

Fuse ratings are:

|     |  |
|-----|--|
| IDR | 100/115 V T1.6AL 250 VAC (Slow Blow)       |
| IDR | 200/230 V T0.8AL 250 VAC (Slow Blow)       |
|     | 50/60 Hz                                   |
|     | 50 W                                       |
| IGH | 100/115/200/230 V T5AH 250 VAC (Slow Blow) |
|     | 50/60 Hz                                   |
|     | 250 W                                      |

#### 5.2.1 Electrical Safety

On completion of the installation ensure a qualified electrician performs earth bonding and leakage current safety checks for the system on both the single and three phase supplies.

### 5.3 Environment

The following operating environment conditions must be observed;

|                        |                                |
|------------------------|--------------------------------|
| Maximum magnetic field | 50 GAUSS                       |
| Ambient temperature    | 18 to 30 °C                    |
| Atmospheric pressure   | 700 to 1060 mbar(10 to 15 psi) |
| Relative humidity      | 30% to 75% non- condensing     |

### 5.4 Handling and Storage Including Transport

The module may be stored for up to 15 weeks in a storage environment as follows;

|                      |                              |
|----------------------|------------------------------|
| Ambient temperature  | -20 to 45 °C                 |
| Relative humidity    | 30% to 75% (non- condensing) |
| Atmospheric pressure | 700 to 1060 mbar             |

If storage is for less than three days then the following environmental restrictions apply;

|                      |                              |
|----------------------|------------------------------|
| Ambient temperature  | -40 to 45 °C                 |
| Relative humidity    | 30% to 75% (non- condensing) |
| Atmospheric pressure | 700 to 1060 mbar             |

Marking for packaging and handling complies with international standards ISO 780/BS2770

### 5.5 Maintenance

#### *Preventive maintenance*

#### **Warning**

**Access within the equipment and removal of connecting cables is restricted to suitably skilled and competent persons. See WARNINGS and CAUTIONS.**

#### **Maintenance interval**

Every six months see CONNECTIONS below and if required contact the Oxford Instruments service department.

## 5.6 Cleaning

### External cleaning

Interval between cleaning is as required by appearance.

#### Warning

**Ensure that the AC supply to the equipment is isolated at the external disconnect device before cleaning. See WARNINGS and CAUTIONS.**

To remove surface dust and light markings, the equipment may be wiped down using lint free cloth, barely moistened with clean water. For removal of heavy marks, the use of a proprietary aerosol foaming cleaner is permissible. Test carefully on a small inconspicuous area to ensure that the product does not damage the surface finish.

## 5.7 Connections

### Warning

**High voltage hazard. Ensure that the AC supply to the equipment is isolated at the external disconnect switch before accessing any connection.**

Check all gas hoses, cables and connections to the equipment for mechanical security and ensure all covers are securely fixed in place.

### Mains cord selection

Mains supply cord shall be rated for the maximum current for the equipment and the cable used shall meet the requirements of IEC227 or IEC245, mains cords certified or approved by any recognised national test house are regarded as meeting this requirement.

Green/Yellow covered conductors shall be used only for connection to protective conductor terminals.

## 5.8 Mounting Instruction

The equipment is housed inside a 19 inch, 12U rack. The rack is usually placed on a bench or table with access to the rear for connections.

## 5.9 Sensor Connections

Connections to the sensors are by means of three 9 way D-sockets on the rear panel of IDR.

|          |  |
|----------|--|
| Sensor 1 | Mix. Ch. Temperature (FemtoPower) (2200 ohm RuO <sub>2</sub> ) |
| Sensor 2 | 1 K Pot Temperature (2200 Ohm RuO <sub>2</sub> )               |
| Sensor 3 | IVC Sorb Temperature (270 Ohm AB)                              |

Changes were required because the FemtoPower input card must occupy the Sensor 1 position in the IDR. Firmware changes were made to compensate for this, so that apart from the different position of the input connectors, the changes do not affect the user. The pin connections for the input sensors are:

|   |   |
|---|---|
| 1 | Input High  |
| 2 | Input Low for Normal Applications                               |
| 3 | Input GND (Linked to pin 2, isolated from supply GND)           |
| 4 | Current Source +ve  |
| 5 | Current Source -ve  |
| 6 | Not used  |
| 7 | Not used  |
| 8 | Input Low for Thermocouples with RT Ref. Junction               |
| 9 | Chassis Ground for Sensors 2 & 3, Internal shield for Channel 1 |

Connections between this socket and the actual sensor will vary with the type of sensor in use, as shown in the table below.

|             | <b>Thermocouple</b> | <b>Metal Resistor</b> | <b>Ge/Carbon Resistor</b> | <b>Si/GaAs Diode</b> |
|-------------|---------------------|-----------------------|---------------------------|----------------------|
| Input High  | V+                  | V+                    | V-                        | V-                   |
| Input Low   | V-                  | V-                    | V+                        | V+                   |
| Current +ve | n/c                 | I+                    | I+                        | I+                   |
| Current -ve | n/c                 | I-                    | I-                        | I-                   |

Note that the polarity of the voltage input connections is reversed for semiconductor resistors and diodes. For these sensors, the sensor resistance or sensor voltage falls with increasing temperature.

## 5.10 Dilution Unit Connections

A fourth 9-way D socket provides connections to the heaters on the dilution unit. The pin connections are:

|   |                        |
|---|------------------------|
| 1 | IVC Sorb Heater +      |
| 2 | IVC Sorb Heater -      |
| 3 | Still Heater +         |
| 4 | Still Heater -         |
| 5 | Mix. Chamber Heater I+ |
| 6 | Mix. Chamber Heater V+ |
| 7 | Mix. Chamber Heater V- |
| 8 | Mix. Chamber Heater I- |

Note that the -ve terminals of all heaters are linked to a common ground within the IDR, so there should be no common connections on the heaters. For the mixing chamber heater, separate current feed and voltage sense wires are provided to allow an accurate measure of the power delivered to the heater. If this facility is not required, the V+ and I+ leads and the V- and I- leads should be joined together at the connector.

## 5.11 Cryostat Connections

For convenience, the individual sensor connections and the heater connections are linked together with the main IGH unit and brought out to a single 37 way D socket on the IGH rear panel. From here a single cable runs to the cryostat. The pinouts at this 37 way D socket are:

|     |                                |
|-----|--------------------------------|
| 1   | Sorb Sensor Current Source +   |
| 2   | Sorb Sensor Input Low          |
| 3   | 1K Pot Sensor Current Source + |
| 4   | 1K Pot Sensor Input Low        |
| 9*  | Mix Chamber Sensor Current +   |
| 10* | Mix Chamber Sensor Input Low   |
| 17  | Sensor Common Input High       |
| 18  | Sensor Common Current -        |
| 19  | Sorb Heater +                  |
| 20  | Sorb Heater -                  |
| 21  | Still Heater +                 |
| 22  | Still Heater -                 |
| 23  | Mixing Chamber Heater +        |
| 24  | Mixing Chamber Heater -        |

Note that the items marked with an asterisk apply only to units prior to the introduction of FemtoPower. In units with FemtoPower a separate cable links the Sensor 1 input on the IDR directly to the cryostat in order to minimise any possibility of pick up on the leads to this sensitive sensor. It is important to realise that the purpose of this is not to prevent errors in the measurement of resistance. It is to ensure that no signals enter this wiring that can cause heating of the sensor resistor.

To achieve this it is important to use the cable shield correctly on the cable joining the cryostat to the IDR Sensor 1 input. On this cable ONLY, the shield should be linked to the connector shell at the cryostat end, but at the IDR end it must NOT be linked to the connector shell. Instead it must link to pin 9 of the connector. This carries the shield through to a separate shielding enclosure surrounding the FemtoPower input stage, which is not directly connected to the chassis ground. On all other connectors, cable shields should be connected directly to connector shells.

## 5.12 RS232 Serial Data Line Connections

The bi-directional serial data link from the computer is connected via a 25 way D-socket on the rear panel. IDR is configured as a DCE with the standard pin outs given below. The majority of computer RS232 interfaces are configured as a DTE and are fitted with a 25 way D plug. For this type of connector, a simple lead connecting pin 1 to pin 1, pin 2 to pin 2 etc. is all that is required. For computers fitted with a 9 way D plug for RS232, (AT style COM port), a standard "AT lead" fitted with a 9 way socket and a 25 way plug is required.

Pin connections at the IDR RS232 socket are:

| Pin | Signal Name | Notes                              |
|-----|-------------|------------------------------------|
| 1   | FG          | Linked to Chassis Ground in IDR    |
| 2   | TD          | Data from Computer to IDR          |
| 3   | RD          | Data from IDR to Computer          |
| 4   | RTS         | Linked to Pin 5 in IDR             |
| 5   | CTS         | Linked to Pin 4 in IDR             |
| 6   | DSR         | Linked to +5 V when IDR is powered |
| 7   | SG          | Linked to Digital Ground in IDR    |
| 8   | DCD         | Linked to +5 V when IDR is powered |

All other pins are open circuit.

IDR does not require signals to be present on any of the "modem control" lines, RTS or DTR (pin 20). RTS is looped back as CTS and logic high levels are returned on DSR and DCD to ensure maximum compatibility with any requirement of the computer.

Voltage levels for the transmitted and received data are:

|                        |          |
|------------------------|----------|
| Tx Data High           | > +5.5 V |
| Tx Data Low            | < -5.5 V |
| Rx Data High Threshold | < +2.6 V |
| Rx Data Low Threshold  | > +1.4 V |
| Max. Rx Input Voltage  | ±30 V    |

Data protocols are:

|               |        |
|---------------|--------|
| Baud Rate     | 9600   |
| Tx Start Bits | 1      |
| Tx Data Bits  | 8      |
| Tx Stop Bits  | 2      |
| Rx Start Bits | 1      |
| Rx Data Bits  | 8      |
| Rx Stop Bits  | 1 or 2 |
| Parity        | None   |

### 5.13 The Oxford Instruments ISOBUS

A unique feature of KelvinoxIGH and other Oxford Instruments products, is the ability to connect a number of instruments simultaneously, to a single RS232 port on a computer and to control each one independently. This is done by means of an ISOBUS cable which carries a single MASTER connector (25-way D socket) and up to eight, daisy-chained SLAVE connectors (25-way D plugs). Each slave connector incorporates full optical isolation so that the slaves are all isolated from the master and from each other. The slaves connectors draw their power from the individual instruments, via the DCD signal on pin 8. The master connector may draw its power from either DTR or RTS signals from the computer.

To use ISOBUS, a special communication protocol is required, which is part of the command structure of Oxford Instruments' products and is described in section 8.5.

### 5.14 GPIB (IEEE-488) Connection (Optional)

If the optional GPIB interface is fitted, connections to the GPIB are made via a standard 24 way GPIB connector. Assignment of the connector pins conforms to the standard IEEE-488.1. Connections should be made using a standard GPIB cable.

GPIB connections should never be made or broken whilst the controller or any of the instruments connected to the Bus are powered up. Failure to observe this precaution can result in damage to one or more instruments.

The GPIB interface complies fully with IEEE-488.1-1987 as a talker/listener, able to generate service requests and respond to serial poll and device clear commands. It does not support parallel polling and has no trigger function. Open collector drivers are used on the bus lines so it does not prevent parallel polling of other devices on the bus. Its complete GPIB capability is specified by the Capability Identification Codes:-

SH1 AH1 T6 L4 SR1 RL0 PP0 DC1 DT0 C0 E1

Two lamps are fitted to the rear panel immediately below the GPIB connector, to assist in diagnosing any GPIB communication problems. The RED lamp lights whenever the IDR is addressed to TALK and the GREEN lamp lights whenever it is addressed to listen. The behaviour of the lamps is very dependent on the GPIB controller in use. Some controllers un-address an instrument at the end of any transaction, in which case the lamps will just blink on for each transaction. Others leave instruments addressed between transactions in which case one or other lamp may remain lit depending on whether KelvinoxIGH was last addressed to talk or to listen.

Before any communication can occur, KelvinoxIGH must be given a unique GPIB address. By default, KelvinoxIGH is supplied with its address set to 24. If this address is already in use by another instrument on the bus, it can be changed from the front panel via the Test Mode.

## 5.15 The GPIB to ISOBUS Gateway

A KelvinoxIGH fitted with a GPIB interface has the ability to act as a GATEWAY to an ISOBUS cable, allowing other instruments to be linked to the GPIB without themselves requiring GPIB interfaces. This can enable other Oxford Instruments' products, for which an internal GPIB interface is not available, to be linked. It offers the additional advantage of optical isolation between these instruments and the GPIB.

To use the gateway, all that is required is GATEWAY MASTER ADAPTOR. This allows the 25 way ISOBUS MASTER socket to be linked to the 25 way RS232 socket on the IDR. The adapter is a symmetrical 25-way plug to 25-way plug link, with pin connections as shown below.

N.B. Beware of using 25-way plug to 25-way plug adapters, sold as "DCE-linkers" by some suppliers. A variety of different conventions exist for these, not all of which will work as a Gateway Master Adapter. The correct adapter may be obtained from Oxford Instruments.

| 25 WAY PLUG | 25 WAY PLUG |
|-------------|-------------|
| 1           | 1           |
| 2           | 3           |
| 3           | 2           |
| 7           | 7           |
| 6           | 4           |
| 4           | 6           |

The necessary protocols for use as a Gateway Master are included as standard in KelvinoxIGH.

## 5.16 Auxiliary Port Connections

The main function of the auxiliary is to provide a stepper motor drive for the 1 K pot needle valve. In addition it carries a number of spare input and output digital lines, that are presently unused.

Connections to the port are by means of a 15-way D-socket on the rear panel.

The outputs are open-collector transistors (specification as for ULN2803A) and can sink up to 500 mA from a supply of up to 25 volts maximum. When driving an inductive load, it is recommended that a diode is connected across the load to absorb the stored energy.

For low power loads, current may be drawn directly from pin 15, which is connected via a diode and fuse, to the internal unregulated 11 volt line. A maximum total current of 500 mA may be drawn from this source.

Pin connections at the Auxiliary socket are:

|    |                    |                            |
|----|--------------------|----------------------------|
| 1  | Output Bit 0       | (Stepper Motor)            |
| 9  | Output Bit 1       | (Stepper Motor)            |
| 2  | Output Bit 2       | (Stepper Motor)            |
| 10 | Output Bit 3       | (Stepper Motor)            |
| 3  | Output Bit 4       | (Spare)                    |
| 11 | Output Bit 5       | (Spare)                    |
| 4  | Output Bit 6       | (Spare)                    |
| 12 | Output Bit 7       | (Spare)                    |
| 5  | Input K4           | (Spare)                    |
| 13 | Input K5           | (Spare)                    |
| 6  | Input K6           | (Spare)                    |
| 14 | Input K7           | (Spare)                    |
| 7  | +5 V               |                            |
| 15 | Driver Protection. | / +11 V Unregulated Supply |
| 8  | 0 V                |                            |

## 5.17 Relay Box Connections

The function of relay box connector is to provide 24 V power to the relays inside the Pump Control Box and operate the system Vacuum Pumps.

The Pump Control Box is a 3-Phase unit which provides power to the He3, ROOTS and He4 Pumps.

Pin connections at the RELAY BOX connector are:-

|   |      |            |
|---|------|------------|
| 1 | P1-A | 24 V       |
| 2 | P1-B | 0 V        |
| 3 | P1-C | HE3 PUMP   |
| 4 | P1-D | ROOTS PUMP |
| 5 | P1-E | HE4 PUMP   |

## 6 Local Operation

### 6.1 Front Panel Controls on IDR

The front panel controls are grouped together in logically related blocks.

#### **POWER**

A green lamp illuminates whenever the instrument is powered.

#### **ADJUST**

The red RAISE and LOWER buttons provide the main means of adjusting any parameter. They have no effect on their own but are always used in conjunction with one of the other buttons. Whenever a parameter is being adjusted, its current value is shown on the main display. Setting a value involves pressing RAISE and/or LOWER until the required value is shown.

Operation of the RAISE and LOWER controls has been designed to allow large changes to be made relatively quickly whilst at the same time enabling any value to be set exactly. Pressing RAISE or LOWER briefly will cause the value to change by one unit. If the button is held in, the last figure will start to change at about 5 units per second. After 2 seconds, an approximately 10-fold increase in rate will occur, followed after further 2 second intervals by two more rate increases. Altogether there are four different rates. Whenever RAISE or LOWER is released, the next lower speed will be selected. This allows the user to "home-in" on the required value most ergonomically.

A secondary use of RAISE and LOWER is in conjunction with LOC/REM, to enter the TEST & CONFIGURATION mode, as described below.

As well as their use for adjusting parameters associated with IDR itself, RAISE and LOWER are used to change the state of the pumps and valves comprising the IGH unit.

#### **CONTROL**

Control of the instrument may either be LOCAL from the front panel, or REMOTE via the RS232 interface. The LOC/REM button may be used to switch between LOCAL and REMOTE.

When LOCK is lit, the instrument is locked into either local or remote control and the LOC/REM button has no effect. At power up, KelvinoxIGH is locked in LOCAL, since at that time the instrument has no way of "knowing" if there is a computer connected to the RS232 interface.

When KelvinoxIGH is in REMOTE, many of the front panel controls are disabled. Those controls which only affect the display, will still work but those which could change the operation of the instrument will not. If LOCK is lit whilst in REMOTE, all the front panel controls are inoperative.

The LOC/REM control button has a number of secondary SELECT functions which are obtained by pressing this button whilst one or more other buttons are held depressed. If LOC/REM is pressed whilst both RAISE and LOWER are held in, KelvinOXIGH enters the TEST mode (described elsewhere). If LOC/REM is pressed whilst the CAL button is held in, current calibration and configuration data is STORED in the non volatile memory and so is retained at power-up.

### **TEMPERATURE CONTROL**

The IVC sorb and the Mixing Chamber may each be operated under temperature control using their respective sensors to monitor their temperature. Pressing either the SORB or MIXING CHAMBER buttons may be used to toggle temperature control ON and OFF for these functions. The associated lamp lights when control is operating. RAISE and LOWER may be used, whilst the corresponding button is pressed, to adjust the set temperature for control.

The IVC sorb is warmed to release exchange gas into the IVC when initially cooling the fridge. It would not normally be used whilst the fridge is in operation. It is therefore good practice to lower the set point for the sorb to its minimum value after use. Then if the SORB button is subsequently pressed by mistake, it will not warm the sorb significantly.

Before controlling the temperature of the mixing chamber, it is a good idea to select an appropriate heater range, using the 2  $\mu$ W to 20 mW buttons to a value appropriate for the intended control temperature. Whilst controlling, the delivered heater power will be varied between zero and the maximum value selected by the range button. Changing the power range whilst operating under temperature control is not recommended. It will produce a large step disturbance to the control, from which the system may take some time to recover.

Prior to the introduction of FemtoPower, temperature control of the mixing chamber was only possible using an external thermometer and temperature controller. In this case, the section of the panel labelled TEMPERATURE CONTROL, was labelled SORB and the two buttons allowed the SORB heater to be operated under fixed power conditions, as well as under temperature control. Operationally there is no benefit in controlling the sorb at fixed power and this facility has now been removed. The only time fixed sorb power is required is when calibrating the sorb heater supply. For this purpose, it is still possible to achieve fixed power (in a non-intuitive way), by pressing the STILL SET POWER button, whilst the SORB button is held pressed after switching sorb temperature control on. The display will switch to showing SORB POWER and RAISE and LOWER may be used to adjust this. As soon as the SORB button is pressed again it will revert to normal sorb temperature control.

### **STILL**

The still heater supply always operates in the constant power mode. RAISE or LOWER may be used to adjust the power level whilst the POWER button is pressed. Pressing the power button without using RAISE or LOWER toggles the heater on and off.

## MIXING CHAMBER

The mixing chamber heater supply operates in the same way as the other two heater supplies. However, in order to cover the wide range of power required for the mixing chamber, five decade range buttons are provided allowing the maximum power to be set anywhere between 2  $\mu$ W and 20 mW. For fixed power operation, the target output power may be set to the required level, by use of RAISE and LOWER, whilst holding the corresponding range button pressed. A separate ON/OFF button is provided for this supply. If required the target power can be set to the required level with the supply in the OFF condition. When it is subsequently switched ON, the pre-set power is delivered to the heater. When the mixing chamber supply is switched OFF in this way, a relay is used to isolate the current leads to the heater. This ensures no leakage currents are able to flow through the heater, ensuring that it really is contributing no power to the mixing chamber. Just setting the power to zero by means of LOWER, whilst leaving the supply in the ON state, will not open this relay and so may contribute a small unwanted heater power.

## DISPLAY

The display section provides a 4½ digit display of heater power or temperature, together with a set of lamps indicating the parameter being displayed and its units. A SELECT button cycles through three temperature sensors and the three heaters in sequence, without affecting the operating conditions of any of the heaters. When the heaters are switched on or their power level altered, the display is automatically switched to show the heater concerned.

When the SELECT button is pressed, to chose a temperature measuring channel, the display will show the Sensor Code for that channel whilst the button is held pressed. For example the display might show **Cr.7b** for the standard Ruthenium Oxide resistance thermometer used for the still.

When displaying the mixing chamber temperature, below 2 K the display autoranges, to show temperature to a resolution of 0.0001 K (0.1 mK). The range for this sensor extends from 6.554 K down to "0.0000 K. It will therefore provide an indication of changing temperature right down to the base temperature of the fridge. However, resistance thermometry in the mK region is notoriously difficult and even with a calibrated sensor, there will be a temperature below which, the indicated value will cease to be an accurate temperature. The display may be used to show temperature changes and to allow temperature control below this point, but to alert the user to the fact that the displayed temperature should not be trusted as an accurate value, the K lamp will flash. By default, this flashing will start when the temperature falls below 20 mK (the lowest temperature for which Oxford offer a calibration). This value may be set from test mode to any chosen value above which you trust your sensor calibration.

Normally, pressing the SELECT button repeatedly, steps the display through all its options in turn. However, if the MIX CH. temperature is being displayed, the first time SELECT is pressed, after a pause longer than 1 second, it will display the range code, for the mixing chamber sensor, without stepping on. This allows two alternative ways of viewing the reading for the Mixing Chamber sensor:-

- If LOWER is pressed after SELECT the sensor Conductance is displayed in micro Siemens. When LOWER is first pressed, the display shows **Cond** to indicate what is happening and the  $\mu$ W and % lamps both light whilst the conductance remains on display.
- If RAISE is pressed after SELECT the sensor Resistance is displayed in kilohms. When RAISE is first pressed, the display shows **res** to indicate what is happening and the W and mW lamps both light whilst the resistance remains on display.

As well as displaying the heater and temperature values associated with the IDR itself, the digital display is also used to display the current setting of the motorised valves in the IGH, whilst these are being changed by means of RAISE and LOWER.

The DISPLAY section of the panel also includes a recessed CAL button. This may be used to calibrate the temperature sensors and also to store calibrations and any system configuration data in non-volatile memory, so that it is retained when power is removed from the KelvinoxIGH. These operations are described in detail later in this manual.

## 6.2 Mimic Panel Controls on KelvinoxIGH

The Mimic Panel is laid out to represent the two gas flow circuits, and the pumps associated with them. Controls and status lamps are provided for each of the pumps and the valves. Digital displays are provided for each of the pressure gauges. To prevent inadvertent changes to the state of the valves and pumps all require a two part operation to change their state. This involves holding the button associated with the required function pressed, whilst pressing RAISE or LOWER on the IDR panel.

The various controls fall into a number of logically related groups.

### PUMP CONTROLS

These are located together at the top right hand corner of the panel. Pressing RAISE whilst holding the pump button pressed, will start the pump. Alternatively pressing LOWER will stop the pump. A red lamp is lit when the pump has been commanded to run. The actual pumps are controlled by logic signals from the Mimic panel which operate contactors in the pump control box. This is normally mounted close to the pumps and may be remote from the Mimic Panel. If it is suspected that a pump is not running, although it has been switched on from the Mimic panel, you should check that power is applied to the control box and that the pump protection circuit has not tripped. Status lamps are provided on the pump control box itself to indicate this.

## **SOLENOID VALVES**

The majority of the valves in the IGH are solenoid operated valves which may be in one of two states, open or closed. All the solenoid valves will be closed when KelvinoxIGH is first powered up. Opening the valves is achieved by pressing RAISE whilst holding the valve button pressed. A lamp associated with the valve will light to indicate that the command has been accepted. These lamps are colour coded to help in operation of the dilution refrigerator. Valves with a green lamp, will normally be open whilst the refrigerator is operating. Valves with a red lamp may be open whilst the refrigerator is being cooled down or warmed up or for diagnostic purposes. However, they will usually be closed when the refrigerator is operating normally (note that the use of red lamps is not intended to indicate that these valves being open represents a hazardous condition. It merely indicates that the refrigerator is not in normal operation).

## **MOTORISED VALVES**

Three valves on the IGH are driven by stepper motors rather than solenoids. Two of these allow varying rates of gas flow within IGH to help achieve a controlled cool-down. The third is mounted on the cryostat and controls the 1 K pot needle valve in order to maintain a constant level within the pot. Like the solenoid valves, these valves are controlled by a single button on the mimic panel, with a lamp to indicate the valve status. Whilst the button is pressed, the main IDR display shows the current target position for the valve, as a percentage. Thus 0% corresponds to a closed valve and 100% to a fully open valve. RAISE or LOWER may be used as usual to adjust this target position. Whenever the target position is changed, the valve will start to drive towards the new target position. Since it can take several minutes for a valve to move from fully closed to fully open, the valve will normally continue to change after the button is released. Whilst the valve is moving, the valve lamp will light YELLOW. When the valve has reached its target position, the lamp colour will change to RED if the valve is partially open or GREEN if it is fully open (the latter state will normally exist for both the motorised gas valves, when mixture is circulating and the refrigerator is operating normally. Thus the lamp colour follows the convention adopted for the solenoid valves). If the valve is fully closed the lamp will be OFF. A final valve state exists immediately after power up. At this time the valves will attempt to drive to the fully closed position, to ensure that the valves are in a known state. This will take several minutes, during which time the valve lamps will FLASH, in order to indicate that the position of the valves is not yet established. You should not attempt to change the target position to a new value until this process is complete.

## **PRESSURE GAUGES**

Two types of gauge are used. All are displayed on four digit displays on the mimic panel. Three of the gauges, G1, G2 and G3 in the high pressure parts of the circuit, are based on strain gauges and indicate pressures linearly in millibar with a range of 1 to 1000 mB. The other two gauges P1 and P2 employ Pirani gauges. These operate in the constant temperature mode, giving the widest possible range of reading, covering 0.001 mB to 1000 mB. For these gauges, the display autoranges to cover the required range within the four digits. As with all Pirani gauges, the region above 1 mB is not accurately characterised and provides only a coarse resolution. However it is sufficient to confirm normal operation during pump down and to assist in detecting gross leaks. The gauges provide reasonable accuracy consistent with a gauge of this type in the region below 1 mB where they will be used during normal operation of the refrigerator.

## 7 Remote Operation

### 7.1 Introduction

In normal use KelvinoxIGH will be remotely controlled from a computer running the KelvinoxIGH software. Since this software is supplied with the system and will be set up when the Kelvinox is commissioned, it is not normally necessary for the user to become familiar with the command protocols and syntax used between the computer and KelvinoxIGH, in order to operate the system. These details are provided here in this technical manual for those users who wish to modify the software or to write additional software of their own.

Commands to KelvinoxIGH are sent via RS232 (or GPIB if this option is fitted). When in control, the computer has the option of locking out the front panel controls, or of allowing the front panel LOC/REM control to remain active, so that an operator may restore LOCAL operation if required.

### 7.2 Communication Protocols

KelvinoxIGH is always fitted with a Serial (RS232) interface. In addition, an optional GPIB (IEEE-488) interface may be fitted (this would not normally be fitted for systems designed to run with the KelvinoxIGH software). Details of the hardware communication protocols for the two interfaces are given in sections 3.3 and 3.5 respectively.

The same command protocols are used for the Serial and GPIB interfaces.

All commands consist of a string of printing ASCII characters, terminated by a Carriage Return character. A Line Feed character may optionally be sent after the Carriage Return but is ignored by KelvinoxIGH.

Unless the command starts with a "\$" (dollar) character, all commands will evoke a response from KelvinoxIGH. The response will consist of a string of one or more printing ASCII characters and will be terminated by a Carriage Return Character. This may optionally be followed by a Line Feed character.

The response will normally be sent immediately following the command. If a front panel button is pressed when the command is received, the response may be delayed until the button is released. With the Serial Interface in use, the response will be transmitted automatically as soon as it is available. With the GPIB interface the response will be sent when the instrument is next addressed to talk.

If the first character of a command is a "\$", the command will be obeyed but no response will be sent. (See section 5.5).

KelvinoxIGH will accept a command string at all times. If a computer linked by the serial (RS232) port, is unable to accept data from KelvinoxIGH at the full rate of the 9600 baud interface, the "W" command may be used to instruct KelvinoxIGH to send more slowly.

## 7.3 Commands and Responses

Commands to KelvinoxIGH all consist of a single letter, optionally followed by a numeric parameter, the whole being terminated by a Carriage Return. All common operational commands are based on Upper Case letters with mnemonic significance. The response sent by KelvinoxIGH varies depending on the command. Usually it consists of the Command letter received, followed by the value of any data requested. Where a command instructs KelvinoxIGH to carry out an action rather than to send data, the command letter alone will be returned.

If a command is not recognised, has an illegal parameter or cannot be obeyed for any reason, an error response will be sent. This consists of a "?" (question mark), followed by all or part of the command string in question. To simplify error handling in the computer, the "?" will always be the first character returned.

The most common reason for a command error is attempting to execute a control command whilst KelvinoxIGH is in LOCAL control. If in doubt, the "X" command may be used to determine the current status.

## 7.4 Numeric Parameters

All numeric parameters are treated as signed integers and are sent as a string of decimal digits. The range of acceptable numbers is -32768 to +32767. Alternatively, positive numbers in the range 0 to 65535 will be accepted, if preceded by a "#" (hash) symbol. Numbers outside this range will give an error.

For positive numbers, the "+" sign is optional, as are leading zeros. Any spaces, full stops and commas embedded within the number are ignored.

Thus to set a temperature of 20.0 the preferred command form is:

T200

The alternative:

T20.0

would be accepted and correctly obeyed, but the alternative:

T20

would result in a set temperature of 2.0 not 20.0. Hence unless you can be confident that your computer will always send a specific number of decimal places, it is preferable to convert all data to integers. For example in BASIC, the instruction:

```
LET N = INT(10*T)
```

might be used.

The same convention is adopted by KelvinoxIGH in returning numbers to the computer. Thus 23.09 would be returned as +02309. The convention of sending all numbers as integers has been adopted to maintain compatibility with the maximum number of computers. It avoids any problems caused by the various formats used by different machines, to represent floating point numbers.

## 7.5 Use with Oxford Instruments ISOBUS

The Oxford Instruments ISOBUS allows a number of instruments to be driven in parallel from a single RS232 port on a computer, using a special cable assembly.

To allow separate instruments to be distinguished, each is allocated a unique address in the range 0 to 8, held in non-volatile memory.

When operating on ISOBUS an instrument must be able to recognise and respond to commands addressed to it, whilst ignoring commands addressed to other instruments. This is achieved by starting all commands with a special ISOBUS control character.

When more than one powered-up instrument is connected on ISOBUS, no command should be issued which does not have an ISOBUS control character as its first character. Issuing such a command would result in an unintelligible response, as all instruments would reply together (N.B. This will only result in lost data. No hardware damage will be caused).

Following the control character and its parameter (where required), the rest of the command follows the form described above. The response of the instrument depends on the initial control character in the following manner:

@n (At) addresses the command to instrument number n, where n is a digit in the range 0 to 8. This instrument obeys the command and returns its usual response. All other instruments ignore the command and send no reply.

\$ (Dollar) instructs all instruments to send no reply. This is normally used to precede a command being sent to all instruments simultaneously, and prevents a conflict as they all echo the command together.

It may also be used in non-ISOBUS applications if the computer does not wish to receive a response.

It should be used with caution however, since all responses are suppressed, including the "?" error response. Thus the computer has no way of knowing if a command has been received or even if the instrument is connected.

If a command is to be addressed to a specific instrument, but no reply is required, it is permissible to use "\$" and "@n" together. The "\$" should always come first.

& (Ampersand) instructs an instrument to ignore any following ISOBUS control characters. It is included in the ISOBUS protocol to allow instruments whose command repertoire includes "@", "\$", "&" or "!" to be used on ISOBUS. KelvinoxIGH does not require the use of this command.

!n (Exclamation) instructs the instrument that from now on its address is to be n. This command is included here since it is relevant to ISOBUS operation. However, for obvious reasons, it should not be sent when more than one instrument is powered up and connected to ISOBUS (it would result in all instruments having the same address!). The command is intended for initial setting up of instruments, one at a time. To avoid inadvertently changing addresses, the "!" command will only be obeyed following a "U" command with a non-zero password (see section 6). Note that the address set this way is the ISOBUS address, not the GPIB address. The latter cannot be set via the interface, since until an address is defined, GPIB communication is not possible.

## **7.6 The GPIB Interface**

The GPIB Interface is an accessory allowing the KelvinoxIGH to be computer controlled by means of the General Purpose Interface Bus (GPIB), also known as HPIB and IEEE-488 interface.

When installed, it supplements rather than replaces the RS232 Serial Interface. It allows an instrument to be controlled either by GPIB or RS232 (not both simultaneously). In addition when operating under GPIB control, the RS232 interface may be used as a GATEWAY to further OI instruments, not themselves fitted with a GPIB interface.

The instructions which follow assume some basic familiarity with the concepts of the GPIB. This will typically be provided as part of the documentation supporting a GPIB controller card for a computer etc.

Even with the GPIB interface fitted it is still possible to communicate with the instrument via the RS232 interface in the standard way. This is the default condition after power up (or t=0 re-start) and ISOBUS addressing may be used if desired.

Provided the GPIB interface has not been deliberately DISABLED by setting its address to 0 (see section 7.4), it may be switched to the GPIB IN-USE state at any time. This occurs automatically when a GPIB Controller asserts the REN line and addresses the interface either to talk or listen at the GPIB address selected. Once it has been put into the GPIB IN-USE state, it remains in that state until power down or until a t=0 re-start.

### **7.6.1 Sending Commands via the GPIB**

Commands sent via the GPIB follow exactly the same syntax as for the RS232 interface. Commands must be terminated by a Carriage Return <CR> character, (ASCII 13). A Line Feed <LF> may be sent if desired but is not needed and will have no effect (your GPIB controller may send <CRLF> by default). Provided it is operating (as opposed to being in TEST mode) the KelvinoxIGH will accept commands at all times. Where commands produce a response message, this should be read before a further command is issued.

### 7.6.2 Accepting Responses via the GPIB

Messages returned via the GPIB consist by default, of an ASCII character string, terminated by a <CR>. If your controller expects <LF> as a terminating character, this may be achieved by sending an initial "Q2" command after power up. Note that the "Q2" command itself produces no response message but that all subsequent messages are terminated by the <CRLF> pair. The interface never asserts the EOI line at the end of a message, instead allowing either <CR> or <LF> to be used as the End-of-String (EOS) character.

### 7.6.3 The Status Byte, Use of a Serial Poll

One of the problems with a GPIB interface is knowing when a message is available to be read. If a device is addressed to TALK but has no data available, it will wait indefinitely, unless the controller includes a TIMEOUT facility (see section 8.6.10). There are a number of ways by which the controller can determine when data is available. The simplest but least reliable, is to "know" from which command has been sent, whether a reply will be produced. This is fine until something unexpected happens.

A better alternative is to read a STATUS BYTE from the instrument by conducting a SERIAL POLL of it. The KelvinoxIGH interface will always respond to a serial poll and will return a status byte. Three bits in this byte have significance for KelvinoxIGH as follows.

|                          |                          |
|--------------------------|--------------------------|
| Bit 6 (Value 64 decimal) | RQS (Requesting Service) |
| Bit 4 (Value 16 decimal) | MAV (Message Available)  |
| Bit 1 (Value 2 decimal)  | BAV (Byte Available)     |

The bit positions for the SRQ and MAV bits are as specified in IEEE-488.1 and IEEE-488.2 respectively. (Note the convention here is that the Least Significant Bit is Bit 0. This is sometimes referred to as data line D1. Thus lines D1 to D8 correspond to Bits 0 to 7).

The BAV bit is set as soon as at least one byte is available to be read. The MAV bit is set when a complete message up to and including the <CR> or <LF> character is available to be read. The RQS bit indicates that the instrument has requested service by asserting the GPIB SRQ line true.

The Status byte may be read as many times as the controller wishes. The MAV and BAV bits will reflect the current status of the interface at the time the byte is read (but see below). Hence once set, they will remain set until the message has been read. The SRQ bit behaves differently (in accordance with IEEE-488.1). The first time the status byte is read after the interface has requested service, it will be set. The act of reading the status byte clears the service request bit and at the same time allows the interface to release the SRQ line. It will not be asserted again unless a further service request is issued.

KelvinoxIGH updates the status byte every millisecond. Thus if the Status Byte is read within 1 mS of reading data from the interface, the MAV and BAV bits may not yet have been cleared, even though all available data has been read. If these bits are found to be unexpectedly set immediately after a data read, a second read of the Status byte at least 1mS later will confirm whether there really is data remaining.

#### **7.6.4 Use of the Service Request Line**

The interface will issue a service request (by pulling the SRQ line), at the point a complete message becomes available to be read, (i.e. at the point at which MAV is first set), unless the interface is already addressed to TALK at that point. In the latter case no service request is required since the controller is already waiting to read the data or in process of doing so.

Hence use of the SRQ line allows a suitably equipped controller to handle all data from the interface on an interrupt basis. If the controller is not equipped to do this, it may simply ignore the SRQ line and poll the status byte on a regular basis until the MAV bit indicates data is available.

#### **7.6.5 Use of the Device Clear Function**

When the GPIB interface receives a device clear message from the controller, it responds by clearing all the communication buffers to their empty, power-up state. It does not reset any of the temperature control functions to the power-up state. Device Clear may thus be safely used to empty the buffers if these have been filled with a number of unread messages. Device Clear may be sent by either the GPIB DCL message (which clears all connected devices), or by means of the SDC message addressed specifically to its address.

Note that if an ISOBUS GATEWAY is in use, only the buffers in the MASTER instrument are cleared. If data is currently being transmitted from a SLAVE instrument to the MASTER, this will be read into the buffer after it has been cleared.

#### **7.6.6 Use of the Interface Clear (IFC) Function**

Receipt of the single line IFC message clears the GPIB interface functions as specified by IEEE-488.1. It does not clear any pending data in the buffers. Nor does it have any effect on operation of the temperature control function.

#### **7.6.7 Non-Implemented Features of the GPIB**

The GPIB Remote Enable (REN) line is used only to alert the interface to the presence of an active controller. It is not used for LOCAL/REMOTE switching which is carried out by the simpler "C" command, for compatibility with RS232 operation. Similarly the GPIB LOCAL LOCKOUT command and GOTO LOCAL commands have no effect. This functionality too is a part of the "C" command.

The interface does not respond to a Parallel Poll request. By virtue of its use of open collector data buffers, it can however co-exist on the GPIB with other instruments which do have a Parallel Poll facility.

#### **7.6.8 Compatibility with IEEE-488.2**

Compatibility with certain aspects of this extension to the original standard has already been mentioned in a number of places (for example the format of the Status Byte). However, details of the command sequences and formats within messages, error handling and status reporting all follow the existing ITC syntax and protocols used on RS232. This precludes complete compliance with the rather more complex IEEE-488.2 syntax. In particular there is no attempt to support the "Standard Commands for Programmable Instruments" (SCPI).

### **7.6.9 Use of the GPIB Interface as a GATEWAY to ISOBUS**

When the interface is operating in the GPIB IN-USE state, all characters received via the GPIB are echoed back out on the RS232 line. Similarly any characters received on the RS232 are made available to be read by the GPIB controller (with MAV, BAV and SRQ being set appropriately as above). This allows one or more other instruments to be connected to the first instrument using the Oxford Instruments ISOBUS. These may share the benefits of being controlled by the GPIB controller, whilst at the same time enjoying the advantages of optical isolation provided by ISOBUS. To use this GATEWAY, requires only a GATEWAY MASTER ADAPTOR, as described in section 3.6.

No special command protocols are required to access the GATEWAY. All OI instruments fitted with RS232 can be accessed in this way. The command strings sent to individual instruments when used in this way are simply prefaced by their ISOBUS ADDRESSES as described above. Note the distinction between the GPIB address which is common to all the instruments on the GATEWAY and their individual ISOBUS addresses which form a part of the message string, preceded by the "@" character. The ISOBUS GATEWAY MASTER (i.e. the instrument actually fitted with the GPIB interface) always has the ISOBUS address "@0". This must be used when addressing this instrument, since a command sent with no "@" prefix would be seen by all instruments (just as for a simple ISOBUS system).

### **7.6.10 Writing a "Rugged" GPIB Control Program**

A lot of effort has been put into making the design of the GPIB interface as tolerant as possible. However, in any computer interface designed to operate unattended for periods of time, it is essential to assume that data corruption may occur at any time. Usually this is due to static, power line surges, operator error etc. Any controller program should be designed to cope with this. In particular all attempts to write data to or read data from any instrument should have a TIMEOUT facility built in. The GPIB handshake sequence makes it all too easy for lost data to result in the bus hanging indefinitely. When a timeout occurs the controller should attempt to assess what is happening. In the case of the KelvinoxIGH GPIB interface this is best done by means of a serial poll. If this too times out, the next recourse should be to reset the interface by means of the Interface Clear (IFC) line. If a serial poll is still unable to get a response, the controller must assume that the instrument has been switched off, failed or a connector has fallen out. As a last resort it should attempt to alert an operator and/or if possible continue operating the remaining instruments.

## 8 Command List

### 8.1 Operating Commands

**V**      **Version Message**

**Cn**      **Define Control**

- C0      Local & Locked
- C3      Remote (Unlocked)

**On**      **Set on/off state of Still & Sorb Heaters**

- O0      Both OFF
- O1      Still ON, Sorb OFF
- O2      Still OFF, Sorb ON in temperature control
- O3      Still ON, Sorb ON in temperature control
- O4      Still OFF, Sorb ON in power control
- O5      Still ON, Sorb ON in power control

**Snnnn**    **Set Still Power in units of 0.1 mW (Range 0000 to 1999)**

**Bnnnn**    **Set Sorb Power in units of 1 mW (Range 0000 to 1999)**

**An**      **Set Operating Mode for Mixing Chamber Heater**

A0 = off, A1 = fixed heater power, A2 = temperature control

**Mnnnn**    **Set Mix Power in units specified by E (Range 0000 to 1999)**

**En**      **Set Exponent for Mix Power Range**

- E1      Range 2  $\mu$ W, units for M are 0.001  $\mu$ W
- E2      Range 20  $\mu$ W, units for M are 0.01  $\mu$ W
- E3      Range 200  $\mu$ W, units for M are 0.1  $\mu$ W
- E4      Range 2 mW, units for M are 1  $\mu$ W
- E5      Range 20 mW, units for M are 10  $\mu$ W

**Tnnnnn**    **Mix Control Temp. in units of 0.1 mK (0 to 20000)**

**tnnnnn**    **Mix Control Temp. in units of 0.1 mK (0 to 65000)**  
(Firmware version 3.03 onwards)

**pnnnn**    **Mix Control Proportional Band in units of 0.1%**

**innnn**    **Mix Control Integral Band in units of 0.1 minute**

**Knnnn**    **Sorb Control Temperature in units of 0.1 K**

**Gnnn**    **Stepper Valve "G" (V6) in units of 0.1% (Range 0 to 999)**

**Hnnn**    **Stepper Valve "H" (V12A) in units of 0.1% (Range 0 to 999)**

**Nnnn**    **Stepper Valve "N" (1 K pot needle valve) (same units).**

**Pnn Individual Solenoid Valves / Pumps, where:**

$n = 2N$  Opens valve number N (or starts pump)

$n = 2N+1$  Closes valve number N (or stops pump)

$N = 21$  (corresponding to V3A) is a special case. This is main bath exhaust and is a normally open valve, to ensure safety in the event of power failure. For this valve,  $nn = 2N$  closes the valve and  $nn = 2N+1$  opens it.

Examples:

|     |     |                       |     |                       |
|-----|-----|-----------------------|-----|-----------------------|
|     | P2  | Opens valve 1 (V9)    | P3  | Closes valve 1 (V9)   |
|     | P8  | Opens valve 4 (V11A)  | P9  | Closes valve 4 (V11A) |
| but | P42 | Closes valve 21 (V3A) | P43 | Opens valve 21 (V3A)  |

P1 Is a special case and closes ALL valves, with the exception of valve 21 (V3A) which is opened. This is the power up default state. Note that this command does not affect the state of the pumps.

P0 Has no effect.

Mapping of N to valve numbers on mimic panel is:-

|        |                  |
|--------|------------------|
| N = 01 | V9               |
| N = 02 | V8               |
| N = 03 | V7               |
| N = 04 | V11A             |
| N = 05 | V13A             |
| N = 06 | V13B             |
| N = 07 | V11B             |
| N = 08 | V12B             |
| N = 09 | He4 rotary pump  |
| N = 10 | V1               |
| N = 11 | V5               |
| N = 12 | V4               |
| N = 13 | V3               |
| N = 14 | V14              |
| N = 15 | V10              |
| N = 16 | V2               |
| N = 17 | V2A HE4          |
| N = 18 | V1A HE4          |
| N = 19 | V5A HE4          |
| N = 20 | V4A HE4          |
| N = 21 | V3A HE4          |
| N = 22 | Roots pump       |
| N = 23 | (Unlabeled pump) |
| N = 24 | He3 rotary pump  |

**X Reports Status as:**

XxAaCcPppppSsOoEe, where:

"a" is a digit representing MIX heater activity as follows:

- 0 OFF
- 1 ON

"c" is a digit defining CONTROL status as:-

- 0 LOCAL & LOCKED
- 1 REMOTE & LOCKED
- 2 LOCAL & UNLOCKED
- 3 REMOTE & UNLOCKED

"pppp" are 4 hexadecimal digits defining the state of the solenoid valves and pumps.

"s" is a hex digit reporting the status of the three motorised valves. A 1 in the appropriate bit position indicates that the valve is moving.

- BIT 0 VALVE V6 ("G" Command)
- BIT 1 VALVE V12A ("H" Command)
- BIT 2 NEEDLE VALVE ("N" Command)

"x" is a similar digit indicating that the motorised valves are still initialising after power up

"o" is a digit showing ON/OFF status for Still & Sorb

- 0 Both OFF
- 1 Still ON, Sorb OFF
- 2 Still OFF, Sorb ON in temperature control
- 3 Still ON, Sorb ON in temperature control
- 4 Still OFF, Sorb ON in power control
- 5 Still ON, Sorb ON in power control

"e" is single digit defining MIX Heater Power Range

- 0 OFF
- 1 2  $\mu$ W
- 2 20  $\mu$ W
- 3 200  $\mu$ W
- 4 2 mW
- 5 20 mW

**Rnn**      **Read Parameter nn, as follows:**

R0=SET POINT T FOR SORB  
R1=SORB TEMP  
R2=1 K POT TEMP  
R3=MIX CHAMBER TEMP (Over full range, to a resolution of 1mK)  
R4=MIX CHAMBER POWER  
R5=STILL POWER  
R6=SORB POWER  
R7=STEPPER V6 TARGET  
R8=STEPPER V12A TARGET  
R9=STEPPER N/V TARGET  
R10=TEMP REGISTER (for patch etc.)  
R11=CH1 FREQ/4  
R12=CH2 FREQ/4  
R13=CH3 FREQ/4  
R14=A/D I/P GAUGE G1  
R15=A/D I/P GAUGE G2  
R16=A/D I/P GAUGE G3  
R17=A/D I/P 4 (SPARE)  
R18=A/D I/P 5 (SPARE)  
R19=A/D I/P 6 (SPARE)  
R20=A/D I/P PIRANI P1  
R21=A/D I/P PIRANI P2  
R22=RAW A/D I/P 1  
R23=RAW A/D I/P 2  
R24=RAW A/D I/P 3  
R25=RAW A/D I/P 4  
R26=RAW A/D I/P 5  
R27=RAW A/D I/P 6  
R28=RAW A/D I/P 7  
R29=RAW A/D I/P 8  
R30=Mixing Chamber Proportional Band in units of 0.1% (see Note 1)  
R31=Mixing Chamber Integral Action Time in units of 0.1min (see Note 1)  
R32=Mixing Chamber Temperature in units of 0.1 mK (See Notes 1,2 )  
R33=Mixing Chamber Set Point in units of 0.1 mK (See Notes 1,2)  
R34=Mixing Chamber Sensor Conductance in units of 0.1  $\mu$ S (See Note 1)  
R35=Mixing Chamber Sensor Resistance in units of 0.1 kohm (See Note 1)

**Note 1** R30 to R35 only apply to instruments fitted with FemtoPower

**Note 2** R32 and R33 only give valid results for  $T > 3.276$  K for firmware 3.03 and above

**Fnn**      Sets front panel display to a specific parameter as above.

Note that this is intended as a servicing diagnostic command, not an operational command. In many cases the units display will not be meaningful.

## 8.2 System Commands

**Qn** Defines the communication protocol.

|    |                            |
|----|----------------------------|
| Q0 | "Normal" (Default Value)   |
| Q2 | Sends <LF> after each <CR> |

Note that unlike all other commands, the Q command does not produce an echoed response to the computer. Having changed the communication protocol, it automatically clears the communications buffer.

### **Unnnn Unlock**

The UNLOCK command allows access to a set of commands intended for diagnostic and configuration purposes. These have the power to erase or modify the contents of the memory. The U command must be sent with the correct KEY parameter before these commands may be used. The KEY value for these commands is 9999.

A lower level of key protection is provided for the "!" command, to avoid accidental errors. Any non-zero value for U will unlock this command.

Two additional special key values are significant. These are intended specifically to allow a GATEWAY MASTER instrument to be used to load RAM data (via a "Y" command) to a SLAVE instrument, without the data being "obeyed" as commands, by the MASTER. A value of U1234 puts the MASTER to SLEEP, until the specific sequence U4321 is detected. Whilst it is asleep, all data received via the GPIB interface is passed on to the slave but ignored by the master.

Thus the allowed values of U are:

|       |                                  |
|-------|----------------------------------|
| U0    | LOCKED (Power-up Default)        |
| U1    | "!" COMMAND UNLOCKED             |
| U1234 | SLEEP                            |
| U4321 | WAKE UP                          |
| U9999 | "L", "Y" & "Z" COMMANDS UNLOCKED |

### **Wnnnn Wait**

The WAIT command sets a delay interval before each character is sent from IDR via the computer interface. This allows IDR to communicate with a slow computer with no input buffering. The parameter nnnn specifies the delay in milliseconds. It defaults to zero at power-up.

(N.B. the W command does not reduce the rate at which IDR can accept data from computer.)

### **Yn      Load RAM**

The Y command allows the contents of the RAM memory to be loaded in binary, via the serial interface. It is not intended as a user command. If n is omitted or has the value 2, only the first 2 kilobytes of the memory are loaded. If n has the value 8, the entire 8 kilobytes are loaded. In general all calibration parameters of interest are held within the first 2 kB. Note that after loading the memory in this way, the new content will be lost at power-down, unless it has been saved by a STORE sequence as described below.

### **Zn      Dump RAM**

The Z command allows the contents of the RAM memory to be dumped in binary, via the serial interface. It is not intended as a user command. Like the Y command, omitting n or setting it to 2 results in a 2 kB dump. Setting n to 8 gives a full 8 kB dump.

### **[n      Emulate ITC502**

This command switches IDR into a mode where its command interface emulates that of an ITC502 temperature controller. This allows IDR to communicate with the ITC502 interface driver from the Oxford Instruments ObjectBench software. The purpose of this is to allow ObjectBench to design and load sensor calibrations for the IDR thermometry. Sending [1 puts IDR into ITC502 emulation mode. [0 restores normal IDR operation. It is important to remember to restore normal operation by sending a [0 command, **before STORING the new range data**. If data is stored with ITC502 emulation in effect, IDR with power up in the ITC502 emulation mode, which will prevent normal operation. It is possible to tell which mode IDR is in by inspecting the version message returned in response to the "V" command.

## 9 Calibration and Configuration

### 9.1 Temperature Sensor Calibration

To match the IDR temperature measurement channels to the exact characteristics of a specific sensor, a calibration must be carried out near the two ends of the working range. This is achieved by means of the recessed CAL button.

Use SELECT to select the sensor to be calibrated.

Cool the sensor to a known temperature as near to the bottom of the range as possible, or apply an equivalent input from a calibrator.

Press CAL and the display will show **Lo** to indicate that the low point is to be calibrated. Whilst holding CAL pressed, use RAISE and LOWER to set the correct temperature reading. IDR will update the "ZERO" value stored in its memory.

Change to a temperature or calibrator input near the top of the range and repeat the process. IDR will show **Hi** then will update its stored "SPAN" value.

Check that both temperatures read correctly. It should not normally be necessary to repeat the process. IDR automatically corrects ZERO for SPAN changes and vice versa.

Normally IDR automatically decides whether to calibrate the **Lo** or **Hi** point depending on whether the input is in the lower or upper part of its range. If the input value (mV, Ohms, Siemens etc.) is less than 25% of the full input span, the ZERO will be adjusted. If it is above this point, the SPAN will be adjusted (the 25% point has been chosen, to allow users with a 300 K range, to calibrate ZERO at 4.2 K and SPAN at 77 K, if this part of the range is of particular interest). In exceptional cases it may be desirable to over-ride this automatic decision. This is done by holding either RAISE or LOWER pressed when CAL is first pressed.

The Conductance and Resistance Displays for the mixing chamber sensor may also be calibrated, by using the CAL button as above, when either of these variables is on display as described earlier. Calibration of these is completely independent of calibration of the temperature display for the Mixing Chamber. However, the conductance and resistance themselves, interact. The **conductance must be calibrated first**. Any changes to this will affect the resistance calibration.

## 9.2 Storing Calibration and Other Data

Normally after a change has been made to the calibration, it is desirable that the new calibration is retained when the instrument is switched off. Thus the calibration data must be stored. IDR stores an image of the entire content of its RAM memory in an EEPROM. To store the RAM image, the CAL and LOC/REM buttons should be pressed simultaneously. The display will show the message **Stor** briefly indicating that the data has been stored. If the display shows **Prot** instead. This indicates that the internal memory protection switch (S2 on the main board) has been set to the OFF position. Set it to ON and try again.

## 9.3 Entering Test Mode

To calibrate the pressure gauges, it is necessary to put IDR into its test mode. To do this, you should first ensure that IDR is in LOCAL rather than REMOTE control. Then hold the two red buttons RAISE and LOWER pressed, whilst pressing and releasing the LOC/REM button. IDR will display the message:

tEst

to indicate that it is entering test mode. After a second this will change to;

t 00

indicating that Test 0 may now be performed (Test 0 in fact provides the exit from test mode and restarts IDR for normal operation). RAISE and LOWER may be used at this point to step through the possible test functions.

When the chosen "t" number is displayed, LOC/REM may be pressed to access the function. The following table lists the available functions.

|         |   |
|---------|---|
| Test 0  | Restart Normal Operation                              |
| Test 1  | Test Front Panel Display and Lamps (IDR display only) |
| Test 2  | Test Front Panel Buttons (IDR buttons only)           |
| Test 3  | Set GPIB Address                                      |
| Test 4  | Set Front Panel Display Variable                      |
| Test 5  | Calibrate Pressure Gauge Zero Point                   |
| Test 6  | Calibrate Pressure Gauge Atmosphere Point             |
| Test 7  | Assign Sensor Range to an input channel               |
| Test 8  | (Not used)  |
| Test 9  | Set Proportional Band for Sorb Control                |
| Test 10 | Set Integral Action Time for Sorb Control             |
| Test 11 | Set Proportional Band for Mixing Chamber Control      |
| Test 12 | Set Integral Action Time for Mixing Chamber Control   |
| Test 13 | Set Threshold Temperature for Flashing "K" Lamp       |

## 9.4 Pressure Gauge Calibration

The pressure gauges are calibrated at Oxford Instruments, during system test and it should only be necessary to recalibrate these if one of the gauge heads has been replaced. To calibrate a gauge, it is necessary to be able to bring the gauge to a vacuum, better than 10-3 mbar and to bring it to atmospheric pressure, preferably using helium gas.

The vacuum calibration point should be set first, followed by the atmosphere point. Calibrating in this order will prevent interaction between the adjustments.

To carry out the calibration, select Test 5. The display will initially show

0. 01

indicating that the zero point of the first gauge is to be calibrated. By using RAISE or LOWER this may be changed to any value in the range 0. 1 to 0. 8 since the hardware has provision for up to 8 gauge inputs. Inputs 1 to 3 correspond to the three strain gauge sensors, G1 to G3. Inputs 4, 5 and 6 are unused. Inputs 7 and 8 correspond to the two Pirani gauges, P1 and P2.

After selecting the gauge to calibrate, ensure that the gauge head is under vacuum, then press the recessed CAL button. Observe that the mimic panel display for this gauge now reads zero. Use RAISE and LOWER if necessary to carry out the vacuum point calibration on any other gauges. When all the vacuum points have been set, press LOC/REM to exit Test 5.

Now select Test 0 to restore normal operation, whilst retaining the new gauge zero settings. You can then operate valves etc. as appropriate to bring the gauges to atmospheric pressure. Now select Test 6. to repeat the procedure with the gauges exposed to atmospheric pressure. The display will show

A. 1 to A. 8 depending which gauge is to be calibrated.

After calibrating the gauges, do not forget to store the RAM content as described above, or the calibration will be lost when power is removed from the unit.

## 9.5 Setting the GPIB Address

The GPIB interface is normally supplied set to a GPIB address of 24. This may be changed using Test 3. On accessing Test 3, the display will now show G nn where nn is the current GPIB address. Use RAISE and LOWER to display the desired new address, then press LOC/REM to select it. The instrument will revert to the t=0 state. Pressing LOC/REM again will restart the instrument, with the new address in operation. Any address in the range 1 to 30 may be selected (although 31 may be selected, it is not a valid GPIB address since it is reserved for the UNTALK, UNLISTEN functions). Setting the GPIB address to 0 has a special significance. It DISABLES the GPIB interface ensuring that only RS232 operation is possible. To ENABLE it again it is only necessary to return to the t=3 mode and select a new non-zero address.

After the address has been changed, if the new address is to be retained on power down, it must be copied into the Non-Volatile memory by means of the STORE operation described above.

## 10 Servicing

### 10.1 Circuit Description

The majority of the circuitry involved in IDR and IGH is conventional and can be readily understood from the circuit diagrams. The notes which follow cover those areas where some additional explanation may be required.

The heater drive circuitry is electrically isolated from the microprocessor circuits to reduce the risk of noise being coupled into the refrigerator from the digital circuits. Similarly the temperature sensor input channels are isolated from each other and from both the heater and digital circuits.

On the mimic panel, a further isolated supply is generated to run the analogue circuitry associated with the pressure gauges. This includes a reference supply for the A/D converter which may be set to 4.00 volts by means of RV501.

The three heater control circuits in IDR are all similar. Each uses an analogue multiplier AD633 to compute the product of the heater voltage and current, so that the true power being delivered to the heater is known. The multiplier output is compared with the filtered power demand in order to control the series pass transistor. Two adjustments are provided for each heater circuit. Taking the Sorb heater (Circuit CSB1202 sheet 4 of 7) as an example. RV602 sets the zero point for the multiplier, such that the output power just reaches zero for a demand of zero. RV601 sets the full power point such that a demand of 200 mW delivers exactly 200 mW to the heater. The mixing chamber supply is slightly more complicated. Switched scaling resistors are included in both the voltage and current sensing circuits ahead of the multiply, to support the decade range switching. Also a separate voltage sense amplifier U616 is provided to that a 4-wire measurement of voltage across the actual mixing chamber heater to be made. This allows an accurate measurement of the power in the heater itself, irrespective of the lead resistance.

## 10.2 Circuit Diagrams

The following circuit diagrams are included in this section.

| <b>Drawing No.</b> | <b>No. of pages</b> | <b>Description</b>              |
|--------------------|---------------------|---------------------------------|
| CSB1202            | (7 sheets)          | CPU BOARD                       |
| CSB1502            | (1 sheet)           | KEY / DISPLAY BOARD             |
| CQB0302            | (2 sheets)          | INPUT AMPLIFIER BOARD           |
| CQN1102            | (2 sheets)          | FEMTOPOWER INPUT BOARD          |
| CSB2102            | (5 sheets)          | MIMIC PANEL BOARD               |
| CVA0002            | (1 sheet)           | OXFORD INSTRUMENTS ISOBUS CABLE |
| CVG0102            | (1 sheet)           | GPIB INTERFACE                  |

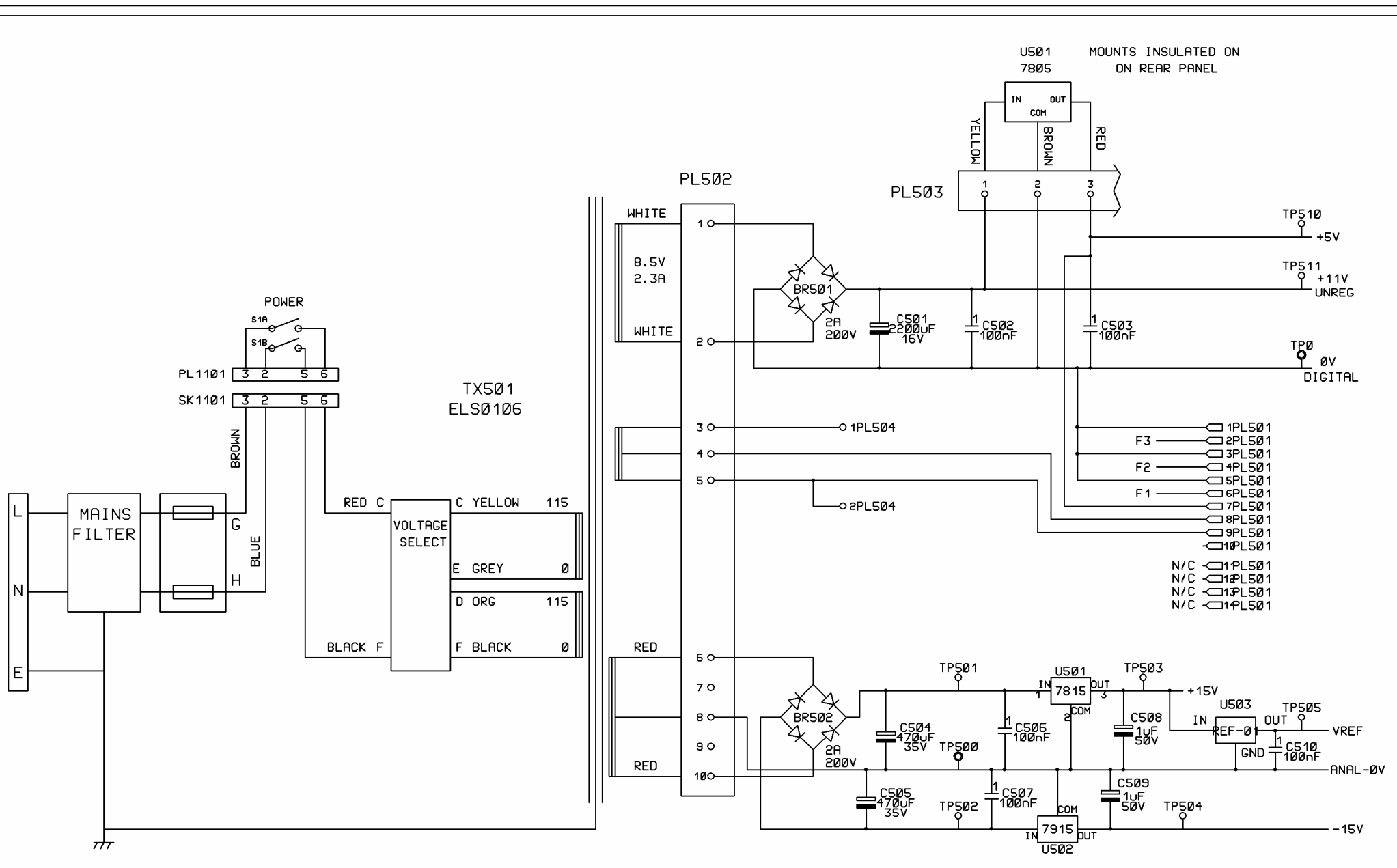

|    |          |  |
|----|----------|--|
| 05 | 20/11/07 | C6 TO 180pF                            |
| 04 | 18/11/03 | C6 CHANGE 100pF TO 150pF               |
| 03 | 20/06/01 | R7 & R8 SWOPPED ON CCT TO MATCH LAYOUT |
| 02 | 6/12/94  | PROTOTYPE MODS                         |
| 01 | 1/8/94   |  |

TITLE

IGH CPU PCB  
POWER SUPPLIES

OXFORD

DRAWING NUMBER

A4 CSB1202 1 of 7

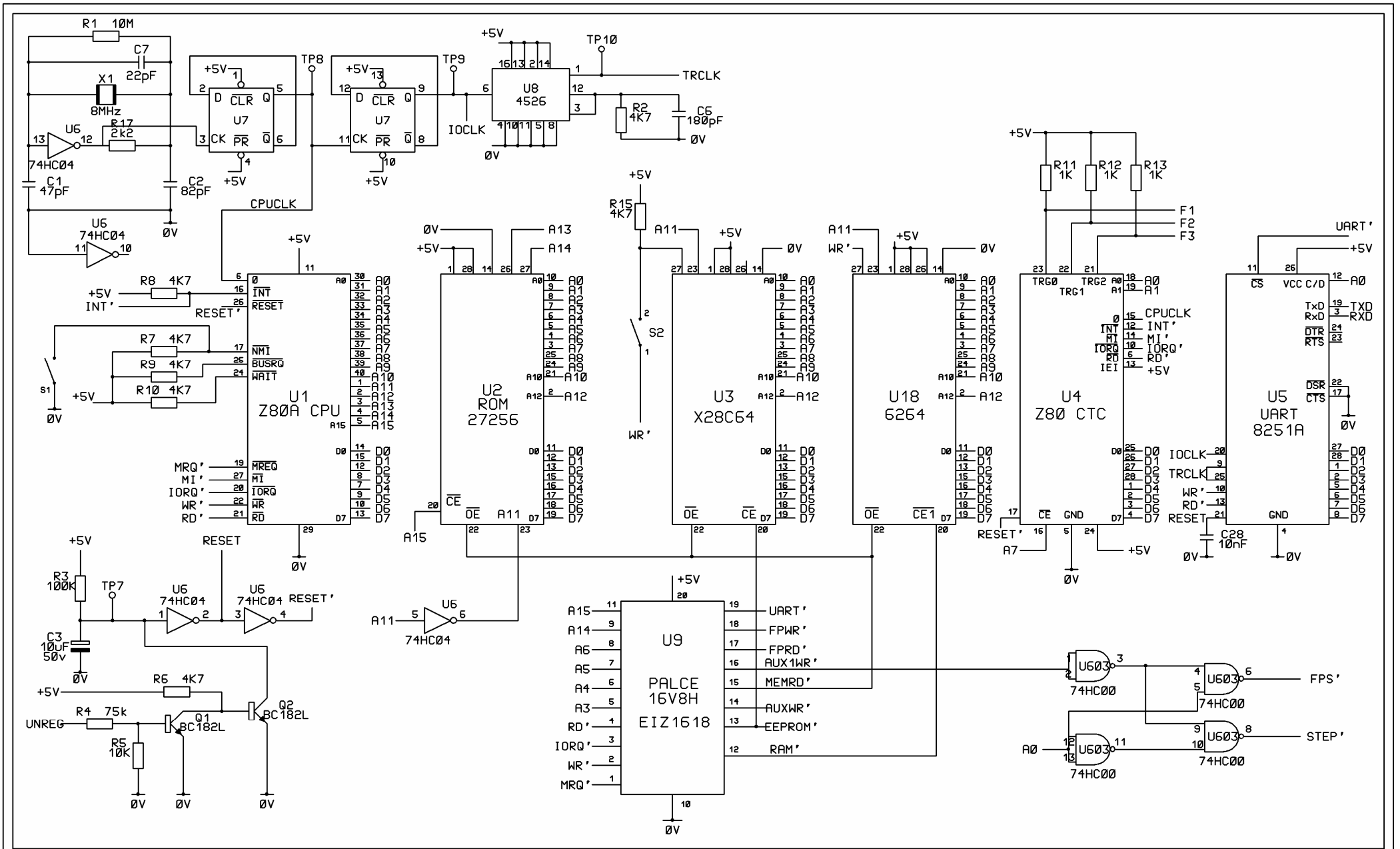

|    |          |  |
|----|----------|--|
| 05 | 20/11/07 | C6 TO 180pF                            |
| 04 | 18/11/03 | C6 CHANGE 100pF TO 150pF               |
| 03 | 20/05/01 | R7 & R8 SWAPPED ON CCT TO MATCH LAYOUT |
| 02 | 6/12/94  | PROTOTYPE MODS                         |
| 01 | 1/8/94   |  |

TITLE

IGH CPU PCB  
CPU LOGIC

OXFORD

DRAWING NUMBER  
A4 CSB1202 2 of 7

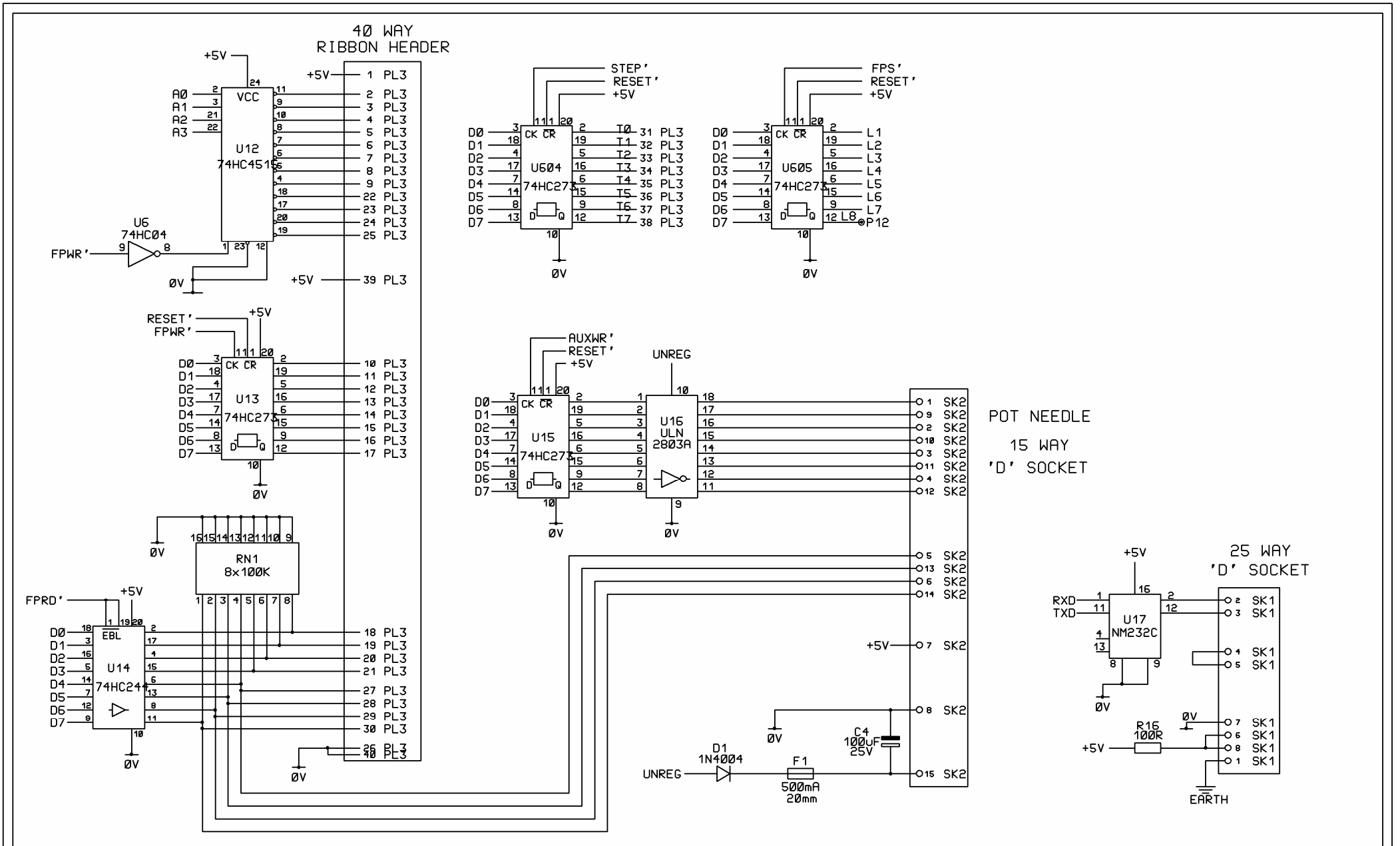

|    |          |  |
|----|----------|--|
| 05 | 20/11/07 | C6 TO 180pF                            |
| 04 | 18/11/03 | C6 CHANGE 100pF TO 150pF               |
| 03 | 20/05/01 | R7 & R8 SWOPPED ON CCT TO MATCH LAYOUT |
| 02 | 6/12/94  | PROTOTYPE MODS                         |
| 01 | 1/8/94   |  |

TITLE  
 IGH CPU PCB  
 MIMIC AND I/O INTERFACE

OXFORD  
 DRAWING NUMBER  
 A4 CSB1202 3 of 7



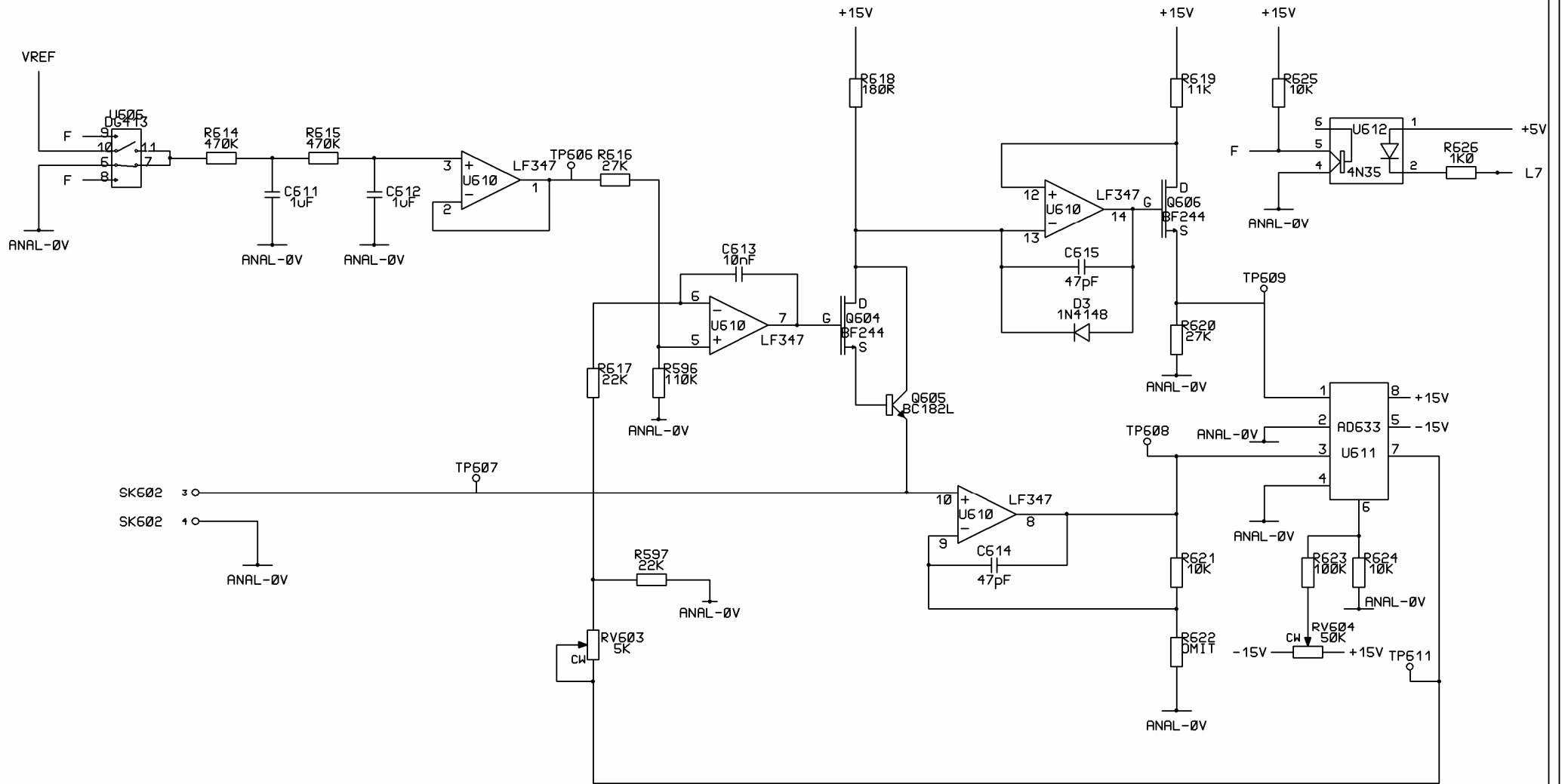

|    |          |  |
|----|----------|--|
| 05 | 20/11/07 | C6 TO 180pF                            |
| 04 | 18/11/03 | C6 CHANGE 100pF TO 150pF               |
| 03 | 20/06/01 | R7 & R8 SWOPPED ON CCT TO MATCH LAYOUT |
| 02 | 6/12/94  | PROTOTYPE MODS                         |
| 01 | 1/8/94   |  |

TITLE

IGH CPU PCB  
STILL HEATER SUPPLY

OXFORD

DRAWING NUMBER

A4 CSB1202 5 of 7



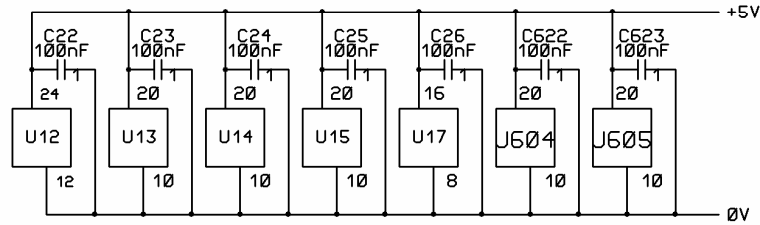
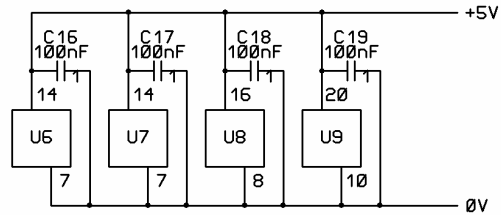
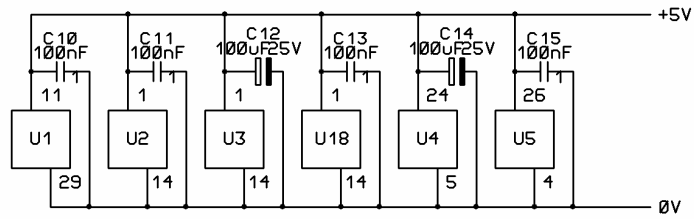
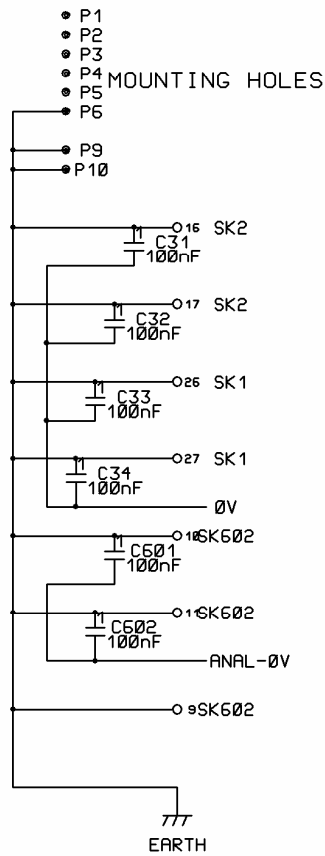

DECOUPLING CAPACITORS TO BE CLOSE TO THE RELEVANT COMPONENT.

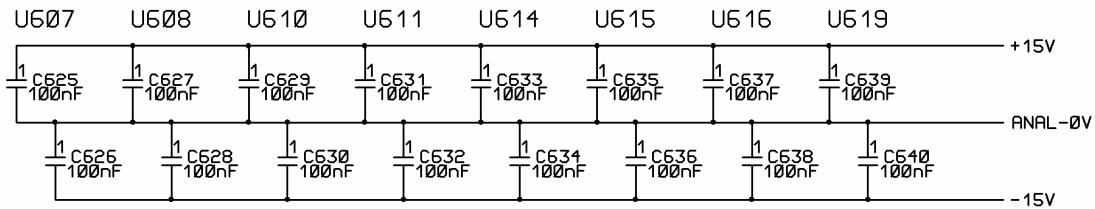
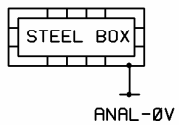

|    |          |  |
|----|----------|--|
| 05 | 20/11/07 | C6 TO 180pF                            |
| 04 | 18/11/03 | C6 CHANGE 100pF TO 150pF               |
| 03 | 20/05/01 | R7 & R8 SWOPPED ON CCT TO MATCH LAYOUT |
| 02 | 6/12/94  | PROTOTYPE MODS                         |
| 01 | 1/8/94   |  |

TITLE

IGH CPU PCB  
SUPPLY DECOUPLING

OXFORD

DRAWING NUMBER  
A4 CSB1202 7 of 7

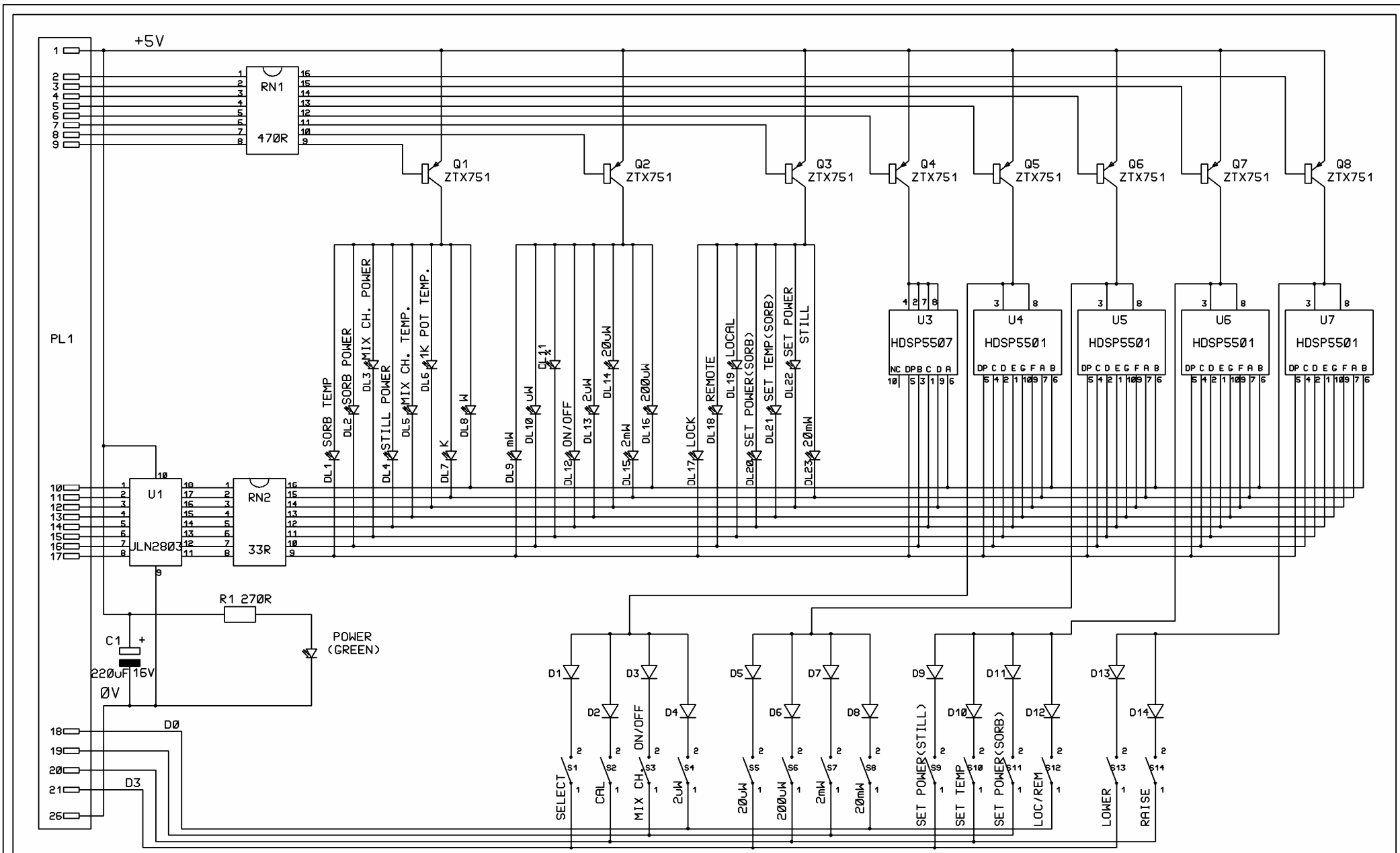

|    |         |                             |
|----|---------|-----------------------------|
| 04 | 14/6/99 | C731 CHANGE U3 BACK TO SIGN |
| 03 | 5:2:98  | U3 WAS SIGN DISPLAY         |
| 02 | 9:12:94 | RN1 WAS 180R                |
| 01 | 21:7:94 | AFS                         |

TITLE  
 IGH KEY/DISPLAY BOARD

OXFORD  
 DRAWING NUMBER  
 A4 CSB1502 1 of 1

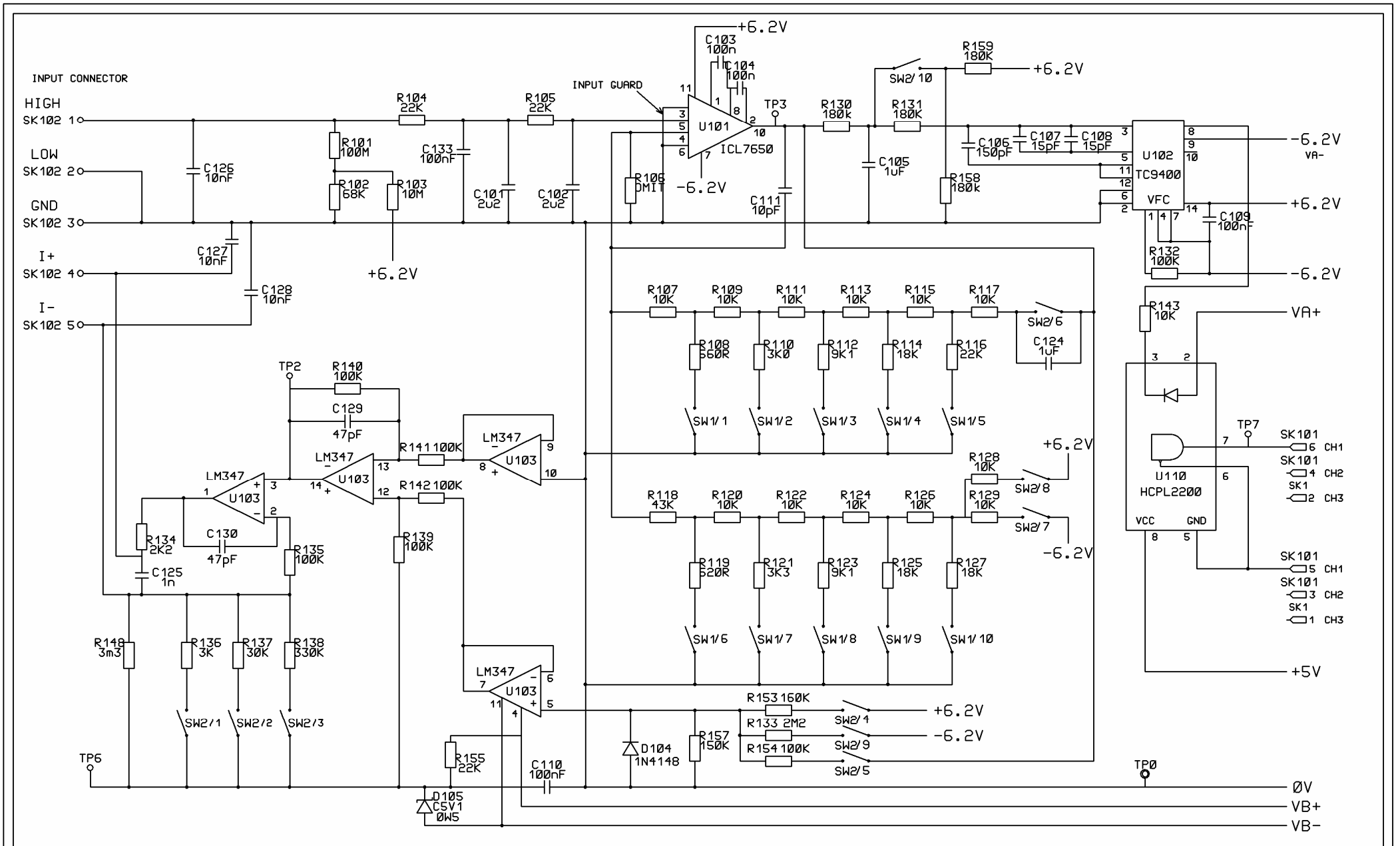

|    |         |   |  |                   |
|----|---------|---|--|-------------------|
|    |         |   | TITLE                                  | OXFORD            |
|    |         |   | ITC INPUT AMPLIFIER PCB<br>CCT DIAGRAM |                   |
| 07 | 22:8:95 | C111 10nF ADDED                         |  | DRAWING NUMBER    |
| 06 | 20:9:93 | REDRAWN, C26-C30, R58 & 59, S2/10 ADDED |  | A4 CQB0302 1 of 2 |

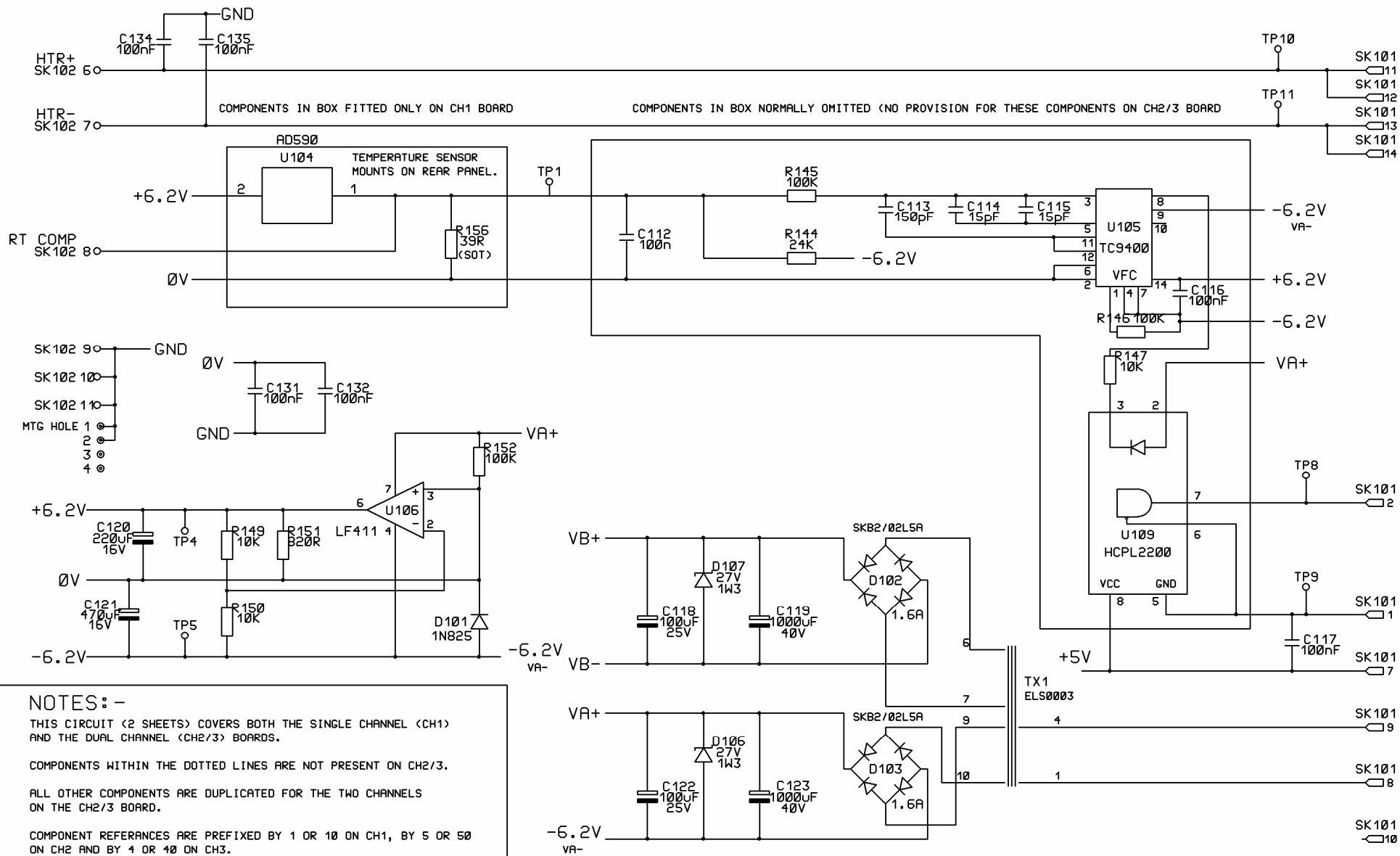

**NOTES: -**

THIS CIRCUIT (2 SHEETS) COVERS BOTH THE SINGLE CHANNEL (CH1) AND THE DUAL CHANNEL (CH2/3) BOARDS.

COMPONENTS WITHIN THE DOTTED LINES ARE NOT PRESENT ON CH2/3.

ALL OTHER COMPONENTS ARE DUPLICATED FOR THE TWO CHANNELS ON THE CH2/3 BOARD.

COMPONENT REFERENCES ARE PREFIXED BY 1 OR 10 ON CH1, BY 5 OR 50 ON CH2 AND BY 4 OR 40 ON CH3.

TITLE

ITC INPUT AMPLIFIER PCB  
CCT DIAGRAM

OXFORD

DRAWING NUMBER

A4 CQB0302 2 of 2

|    |         |   |
|----|---------|---|
| 07 | 22:8:95 | C111 10nF ADDED                         |
| 06 | 20:9:93 | REDRAWN, C26-C30, R58 & 59, S2/10 ADDED |

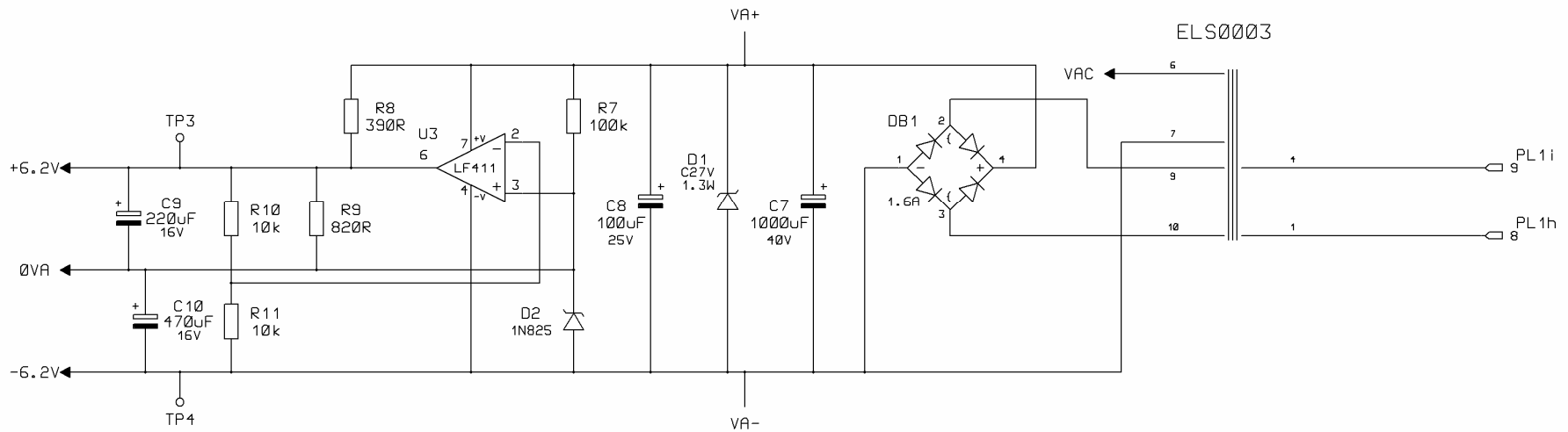
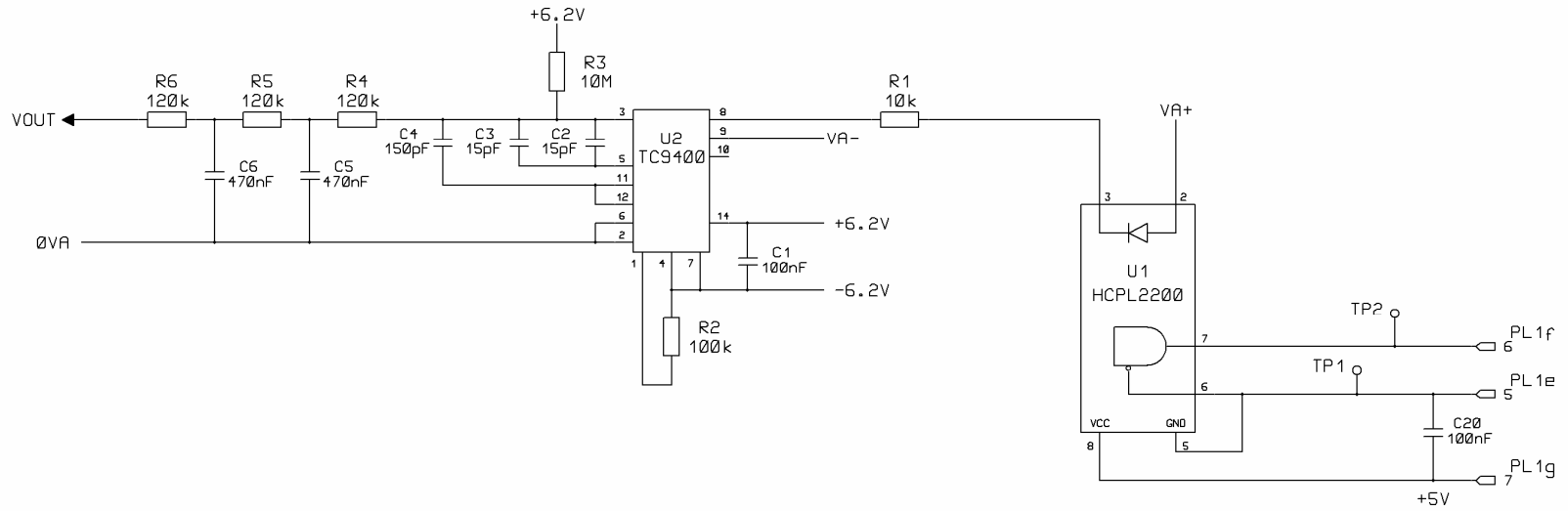

| REV | DATE    | DESCRIPTION    |
|-----|---------|----------------|
| 03  | 7/1/99  | C670           |
| 02  | 24:7:98 | PROTOTYPE MODS |
| 01  | 12:1:98 | IAIN BAKER     |

TITLE

FEMTOPOWER RESISTANCE  
THERMOMETRY FRONT END

OXFORD

DRAWING NUMBER  
A4/CQN1102 SHT 1 OF 2

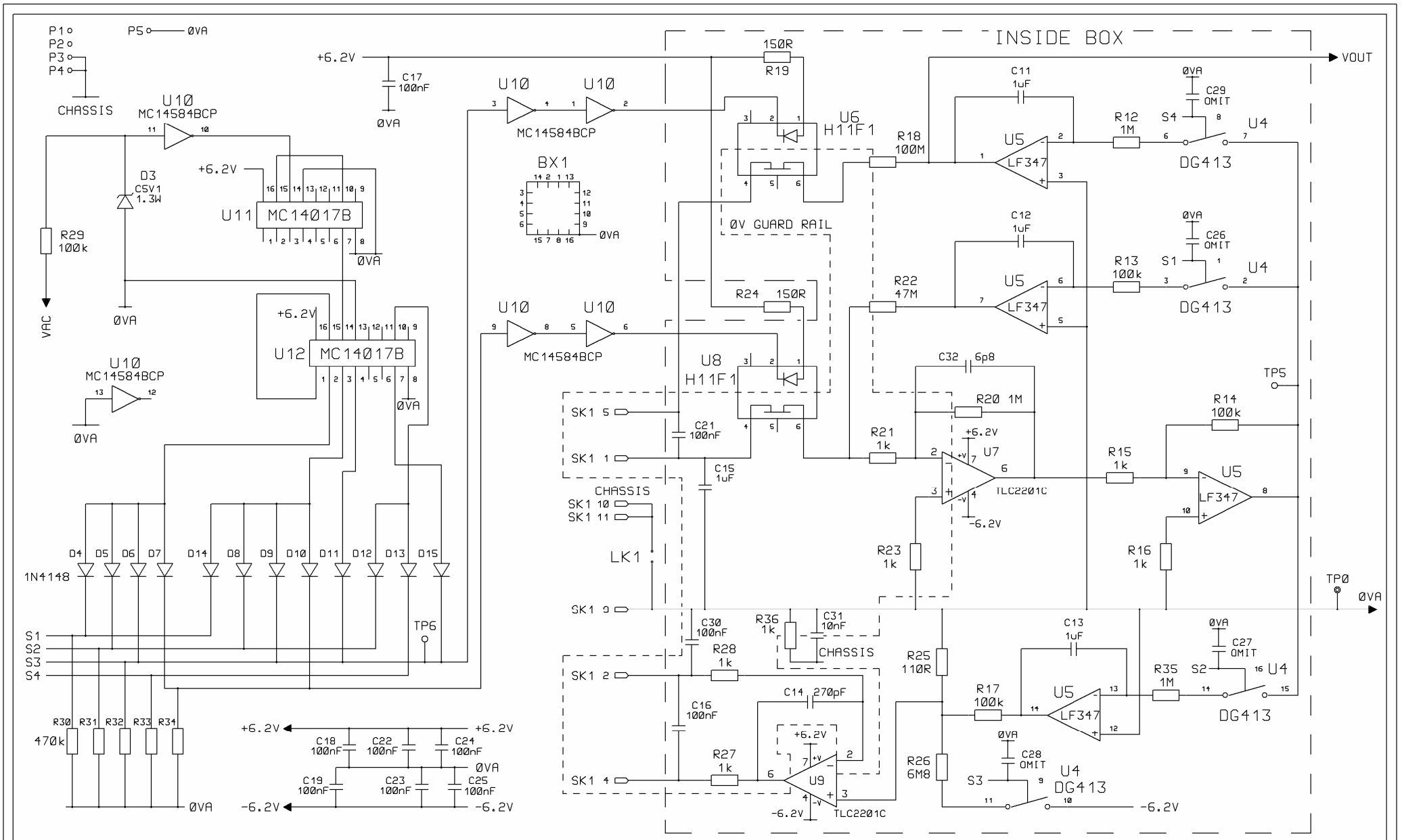

|     |         |                |
|-----|---------|----------------|
| 03  | 7/1/99  | C670           |
| 02  | 24:7:98 | PROTOTYPE MODS |
| 01  | 12:1:98 | IAIN BAKER     |
| REV | DATE    | DESCRIPTION    |

TITLE  
 FEMTOPOWER RESISTANCE  
 THERMOMETRY CCT DIAGRAM

OXFORD  
 DRAWING NUMBER  
 A4/CQN1102 SHT 2 OF 2

PL101  
40 PIN  
RIBBON HEADER

RIBBON CABLE  
TO IDR-PS

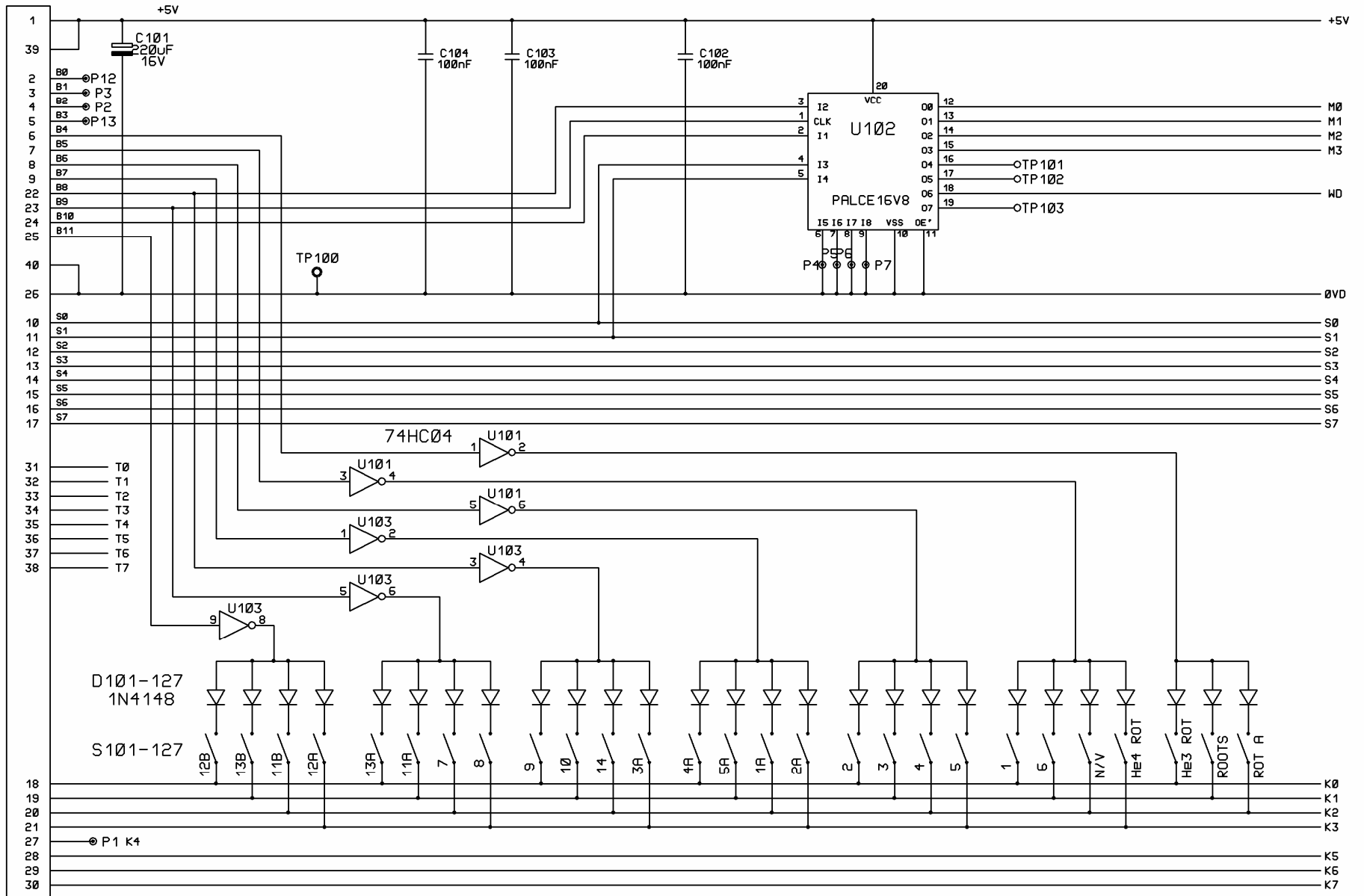

|    |          |                     |
|----|----------|---------------------|
| 07 | 20/11/07 | C307 ADDED          |
| 05 | 19:02:97 | F401 ADDED (EC0539) |
| 04 | 2/10/96  | C477 C15 ADDED      |
| 02 | 12:12:94 | PROTOTYPE MODS      |
| 01 | 22:6:94  | DRAFT ISSUE         |

MIMIC PCB  
KEYS AND DECODE LOGIC

OXFORD

DRAWING NUMBER  
A4/CSB2102 sht 1 of 5

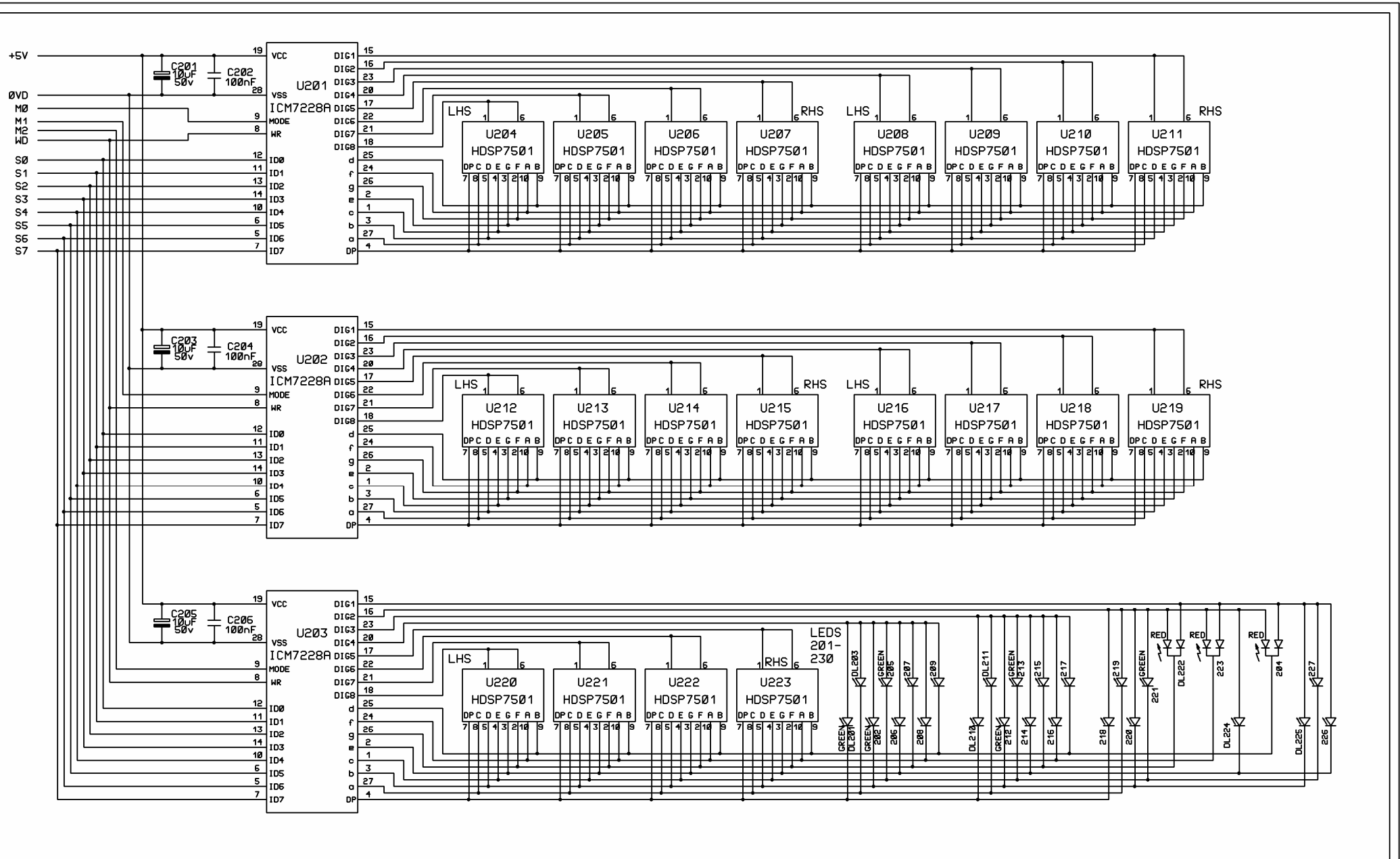

|    |          |                     |
|----|----------|---------------------|
| 07 | 20/11/07 | C307 ADDED          |
| 05 | 19:02:97 | F401 ADDED (EC0539) |
| 04 | 2/10/96  | C477 C15 ADDED      |
| 02 | 12:12:94 | PROTOTYPE MODS      |
| 01 | 22:6:94  | DRAFT ISSUE         |

MIMIC PCB  
DISPLAYS

OXFORD  
DRAWING NUMBER  
A4/CSB2102 sht 2 of 5

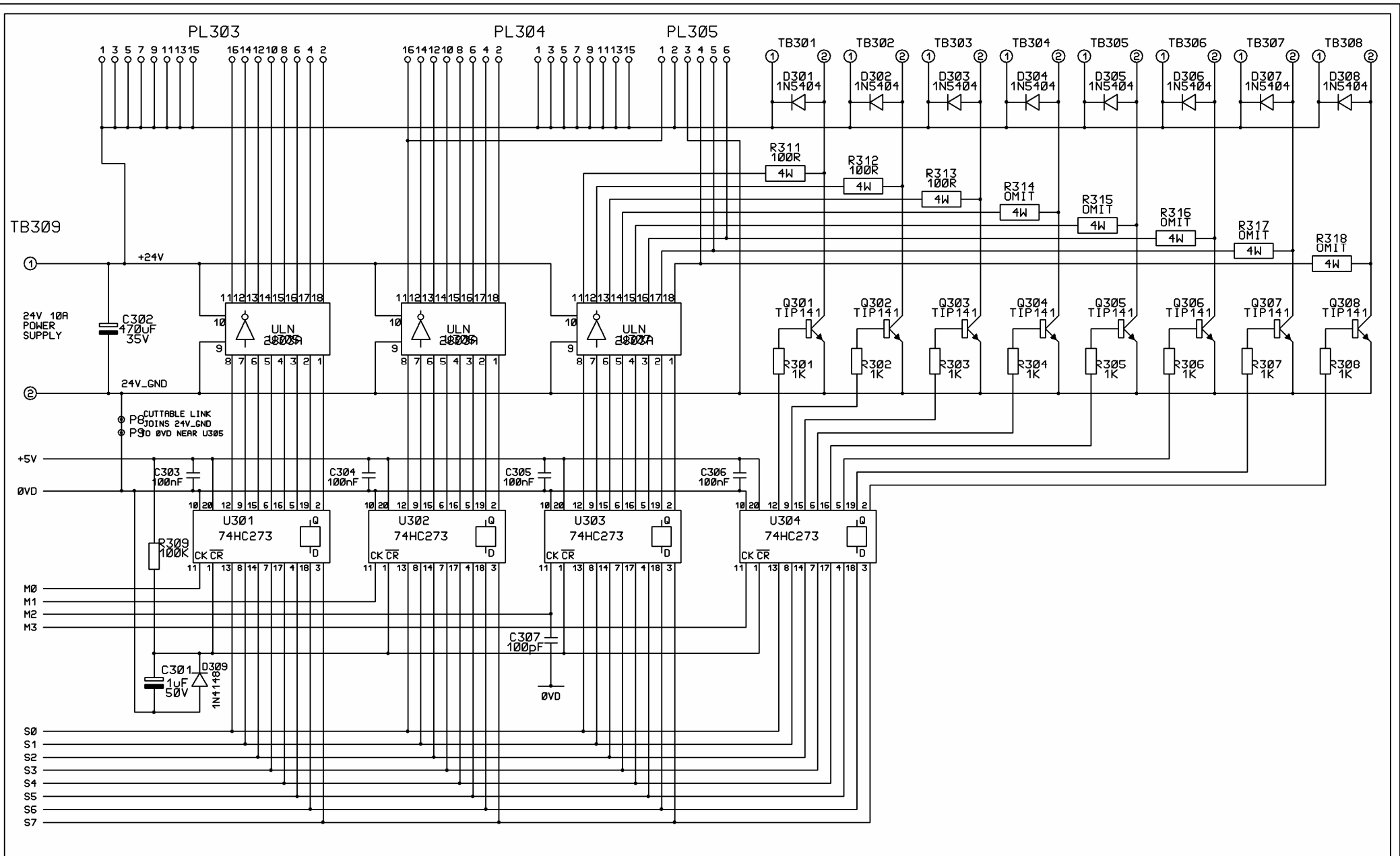

|    |          |                     |
|----|----------|---------------------|
| 07 | 20/11/07 | C307 ADDED          |
| 05 | 19/02/97 | F401 ADDED (ECOS39) |
| 04 | 2/10/96  | C477 C15 ADDED      |
| 02 | 12/12/94 | PROTOTYPE MODS      |
| 01 | 22/6/94  | DRAFT ISSUE         |

MIMIC PCB  
VALVE AND RELAY DRIVERS

OXFORD  
DRAWING NUMBER  
A4/CSB2102 sht 3 of 5

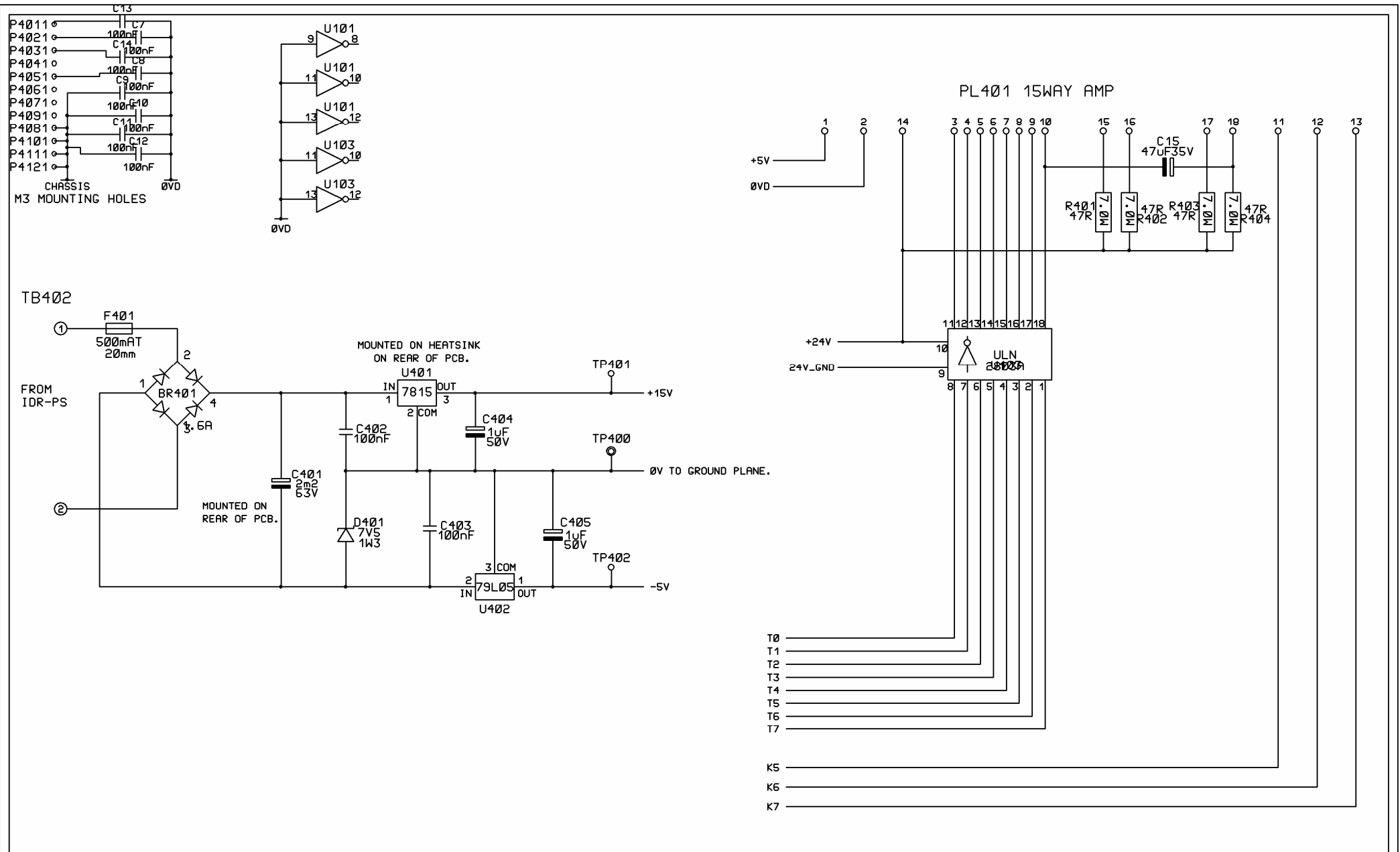

|    |          |                     |
|----|----------|---------------------|
| 07 | 20/11/07 | C307 ADDED          |
| 05 | 19:02:97 | F401 ADDED (EC0539) |
| 04 | 2/10/96  | C477 C15 ADDED      |
| 02 | 12:12:94 | PROTOTYPE MODS      |
| 01 | 22:6:94  | DRAFT ISSUE         |

MIMIC PCB  
ANALOGUE SUPPLY AND  
STEPPER DRIVERS

OXFORD  
DRAWING NUMBER  
A4/CSB2102 sht 4 of 5

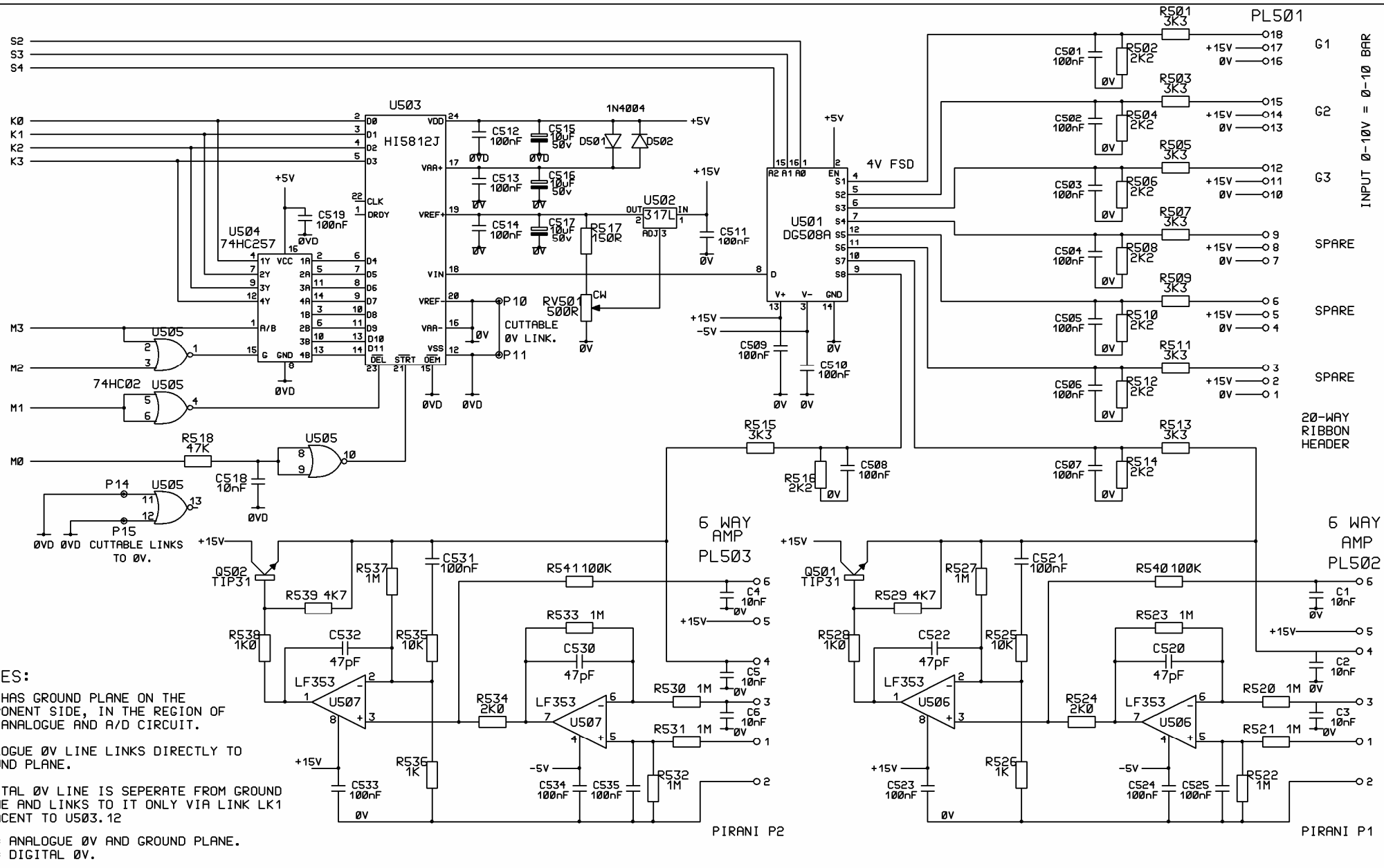

**NOTES:**  
 PCB HAS GROUND PLANE ON THE COMPONENT SIDE, IN THE REGION OF THE ANALOGUE AND A/D CIRCUIT.  
 ANALOGUE 0V LINE LINKS DIRECTLY TO GROUND PLANE.  
 DIGITAL 0V LINE IS SEPERATE FROM GROUND PLANE AND LINKS TO IT ONLY VIA LINK LK1 ADJACENT TO U503.12  
 0V = ANALOGUE 0V AND GROUND PLANE.  
 0VD= DIGITAL 0V.

|    |          |                     |
|----|----------|---------------------|
| 07 | 20/11/07 | C307 ADDED          |
| 05 | 19:02:97 | F401 ADDED (EC0539) |
| 04 | 2/10/96  | C477 C15 ADDED      |
| 02 | 12:12:94 | PROTOTYPE MODS      |
| 01 | 22:6:94  | DRAFT ISSUE         |

MIMIC PCB  
 ANALOGUE I/P AND  
 PIRANI CONTROL

**OXFORD**  
 DRAWING NUMBER  
 A4/CSB2102 sht 5 of 5

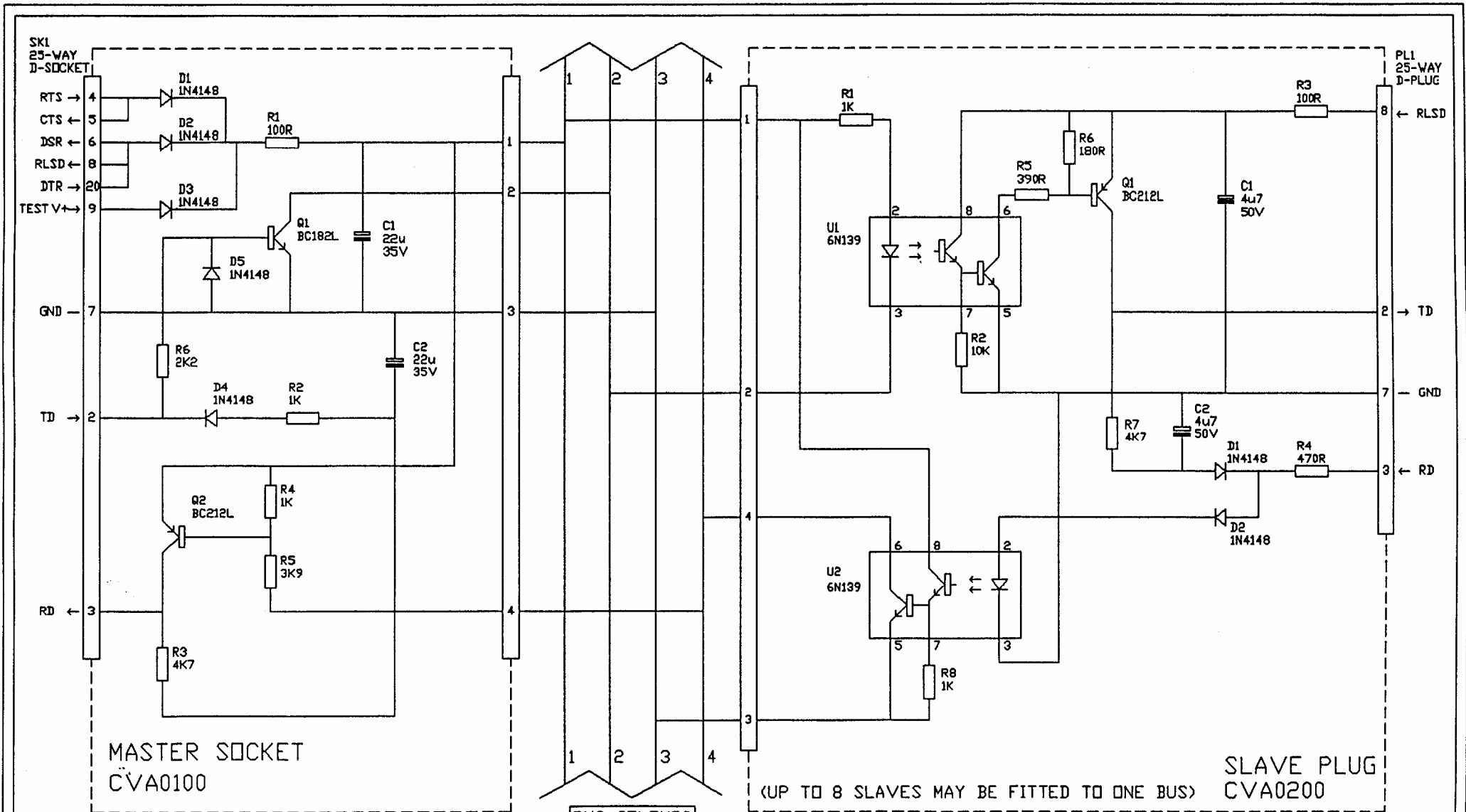

| BUS COLOURS |     |        |
|-------------|-----|--------|
| 1           | V+  | RED    |
| 2           | TD  | BLUE   |
| 3           | GND | BLACK  |
| 4           | RD  | YELLOW |

|         |         |     |  |
|---------|---------|-----|--|
| ISSUE 4 | 26/7/93 | AFS | C1 CONNECTIONS CORRECTED. U1, U2 IDENTIFIER ADDED. |
| ISSUE 3 | 21/6/93 | AFS | REDRAWN  |

OXFORD ISOBUS CABLE

**OXFORD**

DRAWING NUMBER  
A4/ CVA0002

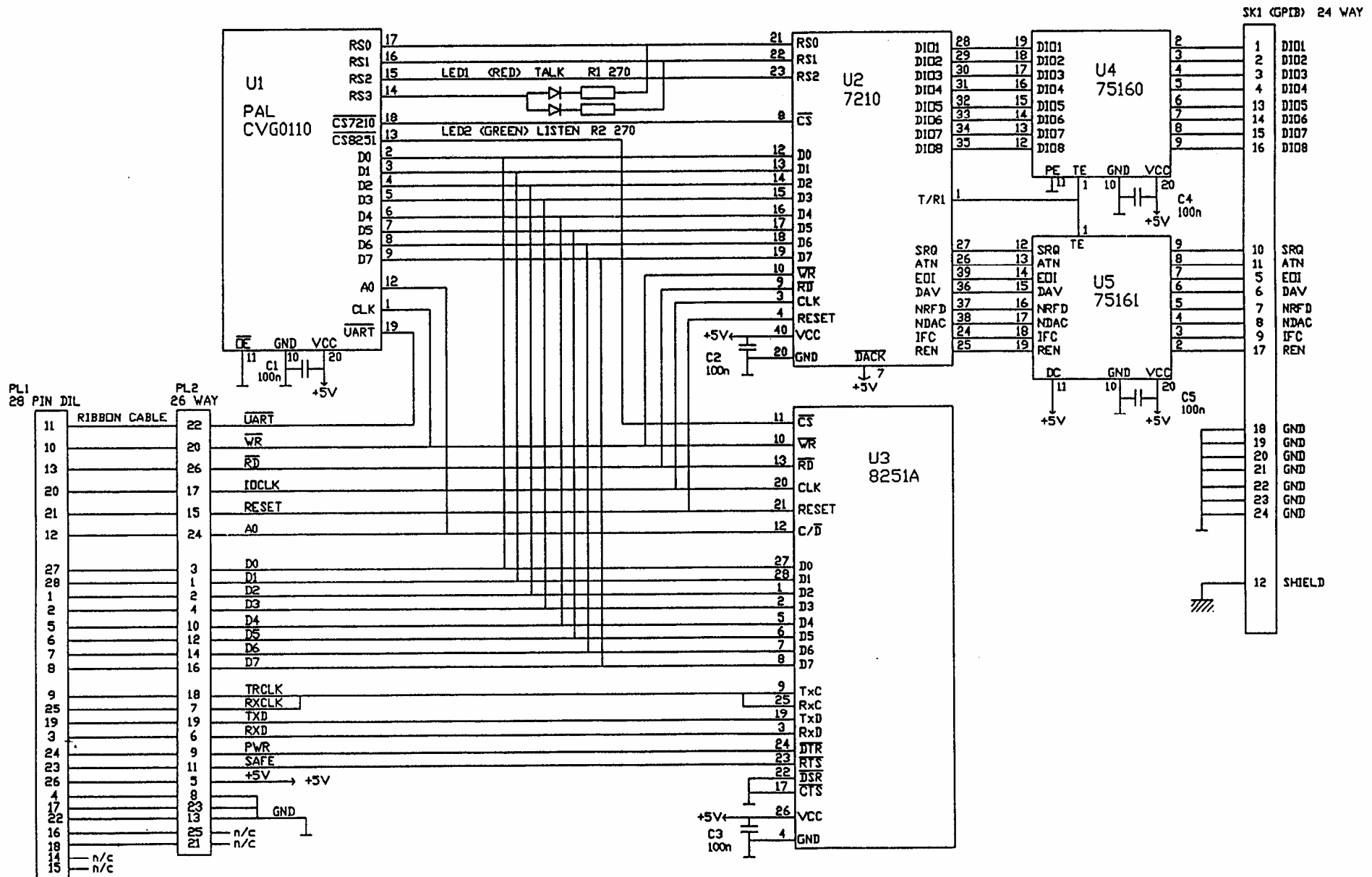

|         |             |   |
|---------|-------------|---|
| ISSUE 3 | 16/3/93 AFS | LED 1 & 2 POLARITY REVERSED, U5 PIN NUMBERING CORRECTED |
| ISSUE 2 | 16/2/93 AFS | PL2 RENUMBERED  |
| ISSUE 1 | 29/1/93 AFS | ORIGINAL  |

## GPIB INTERFACE

# OXFORD

DRAWING NUMBER

A4/ CVG0102