

Operator's Handbook

VC Series

Gas Flow Controllers

Issue 4

January 07

UMC0007

Oxford Instruments NanoScience

Tubney Woods, Abingdon,

Oxon, OX13 5QX, England

Tel: +44 (0)1865 393 200

Fax: +44 (0)1865 393 333

E-mail: nanoscience@oxinst.co.uk

www.oxford-instruments.com



Contents

1	Introduction.....	4
1.1	Safety	4
2	Using the Gas Flow Controller	5
2.1	Mounting the gas flow controller	5
2.2	Pumps.....	5
2.3	Making connections to the gas flow controller	5
2.4	Testing the system for leaks	6
2.5	Controlling the gas flow rate	6
2.6	Testing the system for blockages	6
2.7	Spare plastic lines	6
2.8	Disconnecting the quick couplings.....	7
2.9	Front panel of the VC30 and VC31.....	7

Warnings

Before you attempt to install or operate this equipment for the first time, please make sure that you are aware of the precautions that you must take to ensure your own safety.

© Oxford Instruments NanoScience, 2007. All rights strictly reserved.

You may make hard copies of this manual for your organisation's internal use in connection with the system with which it was supplied, provided that the integrity of the manual is maintained and this copyright notice is reproduced. Other than as permitted above, you may not reproduce or transmit any part of this document, electronically or mechanically without the prior written permission of Oxford Instruments NanoScience.

Oxford Instruments' policy is one of continued improvement. The Company reserves the right to alter without notice the specification, design or conditions of supply of any of its products or services. Although every effort has been made to ensure that the information in this manual is accurate and up to date, errors may occur. Oxford Instruments NanoScience shall have no liability arising from the use of or reliance by any party on the contents of this manual and, to the fullest extent permitted by law, excludes all liability for loss or damages howsoever caused.

The Oxford Instruments Logo is a trademark of Oxford Instruments plc or its subsidiaries. The use of our trademarks is strictly controlled and monitored and any unauthorised use is forbidden.

1 Introduction

This manual covers the VC range of gas flow controllers including:

- VC30 (later versions only) for helium gas
- VC31 for helium gas
- VC41 for helium, nitrogen or air
- VC51 for nitrogen or air

These controllers are designed for use with a continuous flow cryostat or variable temperature insert to monitor and control the flow of a cryogen through the system. The cryostat pressure and the flow rate through the system are shown on the front panel of the controller.

The controller is connected between the cryostat outlet and the pump, and a 0 to 1000 mbar (absolute) pressure gauge is used to measure the pressure in the cryostat. The control valve can be used to adjust the flow rate through the system.

The exhaust of the pump then passes through the controller again. The VC30 and VC31 have a flow meter for helium gas (calibrated from 0 to 2.5 l/hour liquid equivalent). This meter can be used to estimate the flow of nitrogen by multiplying the apparent flow by a factor of 0.5. The VC41 also has a flow meter for air (calibrated from 0.5 to 5 l/minute for gas flow), in parallel with the helium flow meter. The VC51 has only a flow meter calibrated for air. The outlet of the controller can then be connected to a helium recovery system or piped away safely.

A special version of these controllers is also available with a helium flow meter calibrated from 0 to 750 cm³/hour (instead of the standard helium flow meter). This is useful for cryostats which have a low flow rate (for example CF506 and Variox).

1.1 Safety

Before you start to use any cryogenic system you should make sure that you ensure your own safety and the safety of other people working near you. Make sure that you have received the proper training. If in doubt refer to the Oxford Instruments booklet *Safety Matters*.

Hazard

The gas flow controller is often used with a continuous flow cryostat which also has a valve on its inlet. **Make sure that you do not leave both of these valves closed.** A high pressure can be developed if cold gas or liquid trapped in the cryostat warms and expands. The controller is fitted with a pressure relief device to prevent this situation becoming dangerous and to prevent damage to the cryostat. However, the pressure gauge in the controller could still be damaged by a high internal pressure.

Make sure that the cryostat is rigidly supported. The lines between the cryostat and controller are quite rigid and may tip the cryostat over.

2 Using the Gas Flow Controller

2.1 Mounting the gas flow controller

VC30 controllers are built into a freestanding case and cannot be mounted directly in an electronics rack without a suitable adaptor.

VC31, VC41 and VC51 are built into 3U high, half width, electronics cases. They can be mounted in an electronics rack but you must make sure that they are not mounted above any electrical equipment which could be affected by water dripping from the controller. This water could be condensed from the atmosphere by cold gas flowing through the controller.

2.2 Pumps

An oil-free diaphragm pump (such as Oxford Instruments GF3) is usually used to promote the gas flow, by reducing the pressure at the cryostat exhaust.

If the gas flow meter is contaminated with oil its calibration will change. Therefore, if you use another type of pump (for example an oil-sealed rotary pump), it is important to make sure that oil mist from the pump is not carried into the controller. Put an effective oil mist filter between the exhaust of the pump and the controller.

2.3 Making connections to the gas flow controller

All connections are made on the back panel of the controller. 'Quick coupling' connectors are used. They are designed for use with plastic pipe which has an outer diameter of 10 mm and inner diameter of 7 mm. The elbows on the back panel of the controller can be rotated to allow the plastic tubes to point in any direction.

Connect the system together as shown in the system manual. Push the plastic tube into the quick couplings until you feel it click. The tube is then locked in place and cannot easily be pulled out of the coupling by accident.

If you have to cut the tubes prepare the ends of the plastic tubes carefully. Use a sharp knife so that the tube is not flattened as you cut it. The end face of the tube should be square, (perpendicular to the tube axis).

The back panel is labelled so that it is clear how to connect the controller to the pump and the rest of the system. The plastic tube is often a tight fit on the transfer tube or cryostat fitting, and it is difficult to remove it. Therefore an in line connector is supplied to allow the tube to be disconnected easily. This should be at least 1.5 m from the cryostat or transfer tube outlet, so that there is no risk of it freezing and leaking.

If you are using the controller with an older system which is designed for a different plastic tube diameter the new tubes may be a loose fit. A short piece of rubber tube of a suitable diameter can be used to make the connection, but you should make sure that it is not subjected to mechanical shock while it is cold, as it is likely to shatter.

2.4 Testing the system for leaks

After you have connected the pump and controller together (but before you connect the transfer tube and cryostat) you should check that there are no air leaks. Put a rubber bung into the open end of tube which will be connected to the cryostat. Switch on the pump and open the valve on the controller. The reading on the pressure gauge should drop. When the base pressure of the pump is reached close the valve on the controller and watch the pressure gauge. If the pressure starts to rise there is a leak. Check all the external fittings and then, if necessary, check the internal connections.

2.5 Controlling the gas flow rate

On some systems it is best to use the needle valve on the cryogen transfer tube or the cryostat to control the flow through the system. On others the valve on the VC gas flow controller should be used. Refer to the cryostat manual for instructions. In either case the gauge on the controller indicates the pressure in the cryostat.

2.6 Testing the system for blockages

If the cryogen flow rate does not increase as expected during cooldown it is possible that the cryostat or transfer tube is blocked. Make sure that the needle valve on the transfer tube (or cryostat) and the valve on the controller are fully open and observe the pressure on the gauge. Then close the valve on the controller. If the pressure reading on the gauge does not rise to atmospheric pressure quickly there is a blockage in either the transfer tube or the cryostat. Refer to the cryostat manual to find out how to clear the blockage.

2.7 Spare plastic lines

If you are ordering spare plastic lines to use with your gas flow controller it is important that you specify the size of tube that you require. The tube has an outer diameter of 10 mm and an inner diameter of 7 mm. Earlier versions of these controllers used different connectors and lines, which are not compatible.

2.8 Disconnecting the quick couplings

The plastic tube is normally locked into the quick couplings to make sure that it is not accidentally pulled out, but it can be disconnected easily. Push the release ring in, and gently pull the tube out of the coupling. The position of the release ring is shown on the following diagram.

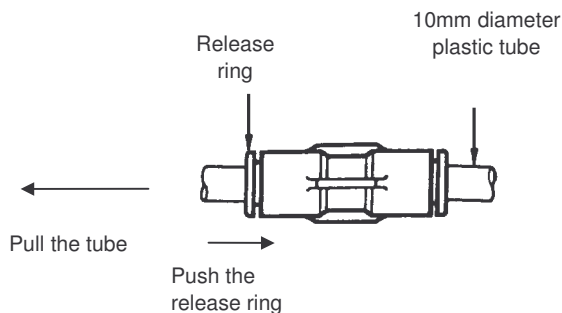

Figure 1 Diagram of an in-line quick coupling, showing the position of the release ring

2.9 Front panel of the VC30 and VC31

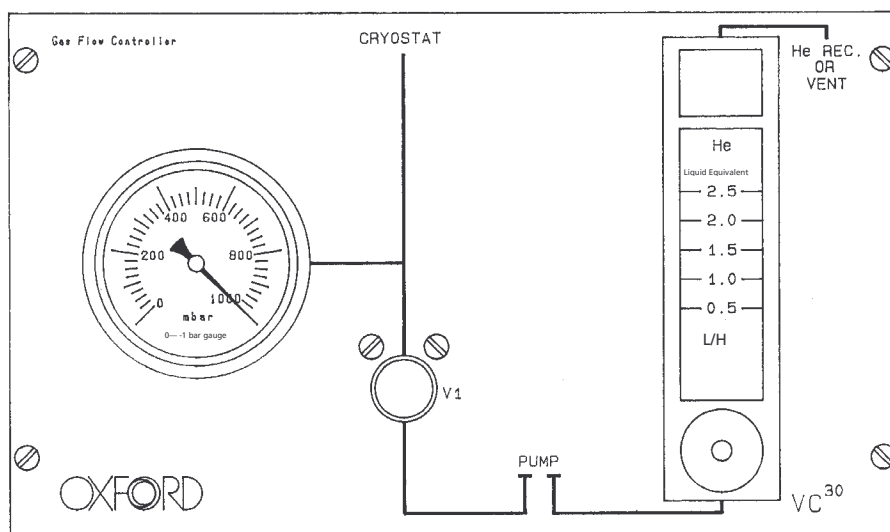

Figure 2 Front panel of VC30 and VC31 gas flow controllers

The front panel of the VC41 is similar but it has an additional air flow meter in addition to the helium flow meter. The layout of the front panel of the VC51 is the same but the flow meter is calibrated for air.