

# Operator's Handbook

# OXSOFT

Integrated Software Environment for LabVIEW drivers

Revision 17

July 06

UMC0043

**Oxford Instruments NanoScience**

Tubney Woods, Abingdon,

Oxon, OX13 5QX, England

Tel: +44 (0)1865 393 200

Fax: +44 (0)1865 393 333

E-mail: [nanoscience@oxinst.co.uk](mailto:nanoscience@oxinst.co.uk)

[www.oxford-instruments.com](http://www.oxford-instruments.com)



## Contents

1	Introduction and System Requirements .....	5
1.1	LabVIEW Versions.....	5
1.2	Computer Specification.....	6
1.3	GPIB.....	6
1.4	Serial Ports.....	6
1.4.1	Serial Ports on a Macintosh.....	6
2	Installing the Software.....	7
2.1	PC Installation.....	7
2.2	Manual Installation .....	8
2.3	Macintosh and Unix Installation.....	8
2.4	Post Installation.....	9
3	How to Start the Software .....	10
4	Configuring the Instruments .....	12
4.1	Communication Principles .....	12
4.2	Communications Parameters.....	15
4.2.1	To Set the ISOBUS address of an Instrument. ....	16
4.3	Step by Step instruction on Configuring and Running an Instrument VI.....	17
4.3.1	Open the Instrument Setup Dialog VI.....	18
4.3.2	Enter values for the Communication Parameters.....	20
4.3.3	Enter values for the remainder of the Setup .....	20
4.3.4	Save the Setup.....	20
4.3.5	Open the Instrument Front Panel VI .....	20
4.4	ITC PID Table Setup .....	20
5	Graphing, Logging and Log Analysis .....	21
5.1	How to use GeneralMonitorSetupDialog.VI.....	21
5.1.1	Adding a Signal .....	22
5.1.2	Removing a signal .....	22
6	Programming with the VIs .....	23
7	Troubleshooting .....	24
7.1	Isolating communications problems .....	24
7.2	GPIB Problems .....	26
8	Teslatron or OXSOF (B/T Environment Software) .....	27
8.1	Introduction.....	27
8.1.1	Teslatron or B/T System Manager.....	27
8.1.2	Sequencer .....	27
8.1.3	Fridge .....	27
8.1.4	Interlocks.....	27
8.1.5	Self Test.....	27
8.2	Configuring the Software.....	28
8.2.1	Teslatron or B/T SetupDialog .....	28
8.2.2	Fridge Setup Dialog.....	28
8.3	How to Use the Software.....	28

8.4	How to Build Your Own Application .....	28
9	Heliox .....	29
9.1	The Heliox panel .....	29
9.2	The Recondense VI .....	29
9.3	The Heliox Setup .....	30
10	The Kelvinox software.....	31
10.1	Software organisation .....	31
10.2	Usage notes .....	31
10.3	The Kelvinox front panel .....	32
10.3.1	Sequences .....	33
10.3.2	Utilities.....	33
10.4	The 4.2 K cooldown sequence .....	33
10.5	The Run-To-Base sequence .....	34
10.5.1	The Fill Pot sequence.....	34
10.5.2	The Condense sequence.....	34
10.5.3	The Circulate sequence .....	34
10.6	The Warm Up sequence .....	34
10.6.1	The Empty Pot sequence.....	34
10.6.2	The Pump sequence .....	34
10.6.3	The Flush sequence .....	34
10.7	The Change Cold Trap sequence .....	35
10.8	The Load Probe sequence .....	35
10.9	The Unload Probe sequence .....	35
10.10	Make Safe .....	35
10.11	The IGH monitor.....	35
10.12	The AVS monitor .....	36
10.13	The 1 K Pot monitor.....	36
10.14	The Quench Monitor.....	36
10.15	The Kelvinox setup.....	37
10.15.1	Valve adjustment.....	37
10.15.2	Gauge monitoring.....	37
10.16	Replacing the 1 K pot with a VariOX Cryostat.....	38
10.17	Using the IGH software.....	38
10.17.1	The IGH front panel .....	38
10.17.2	The IGH Setup.....	38
10.18	The AVS47 Bridge and TS530 Controller.....	39
10.18.2	The AVS47 Bridge with GPIB Interface.....	43
10.18.3	The AVS46 Bridge and TS530 Controller.....	44
10.18.4	Sensor Calibration and Ohm to Kelvin Conversion .....	44
10.19	IGH with FemtoPower Option .....	45
11	The KelvinoxAST software.....	46
11.1	Setup Dialog .....	46
11.2	KelvinoxAST Front Panel .....	46
11.3	KelvinoxAST parameter table .....	47
11.4	The KelvinoxAST Monitor .....	49

© Oxford Instruments NanoScience, 2006. All rights reserved.

You may make hard copies of this manual for your organisation's internal use in connection with the system with which it was supplied, provided that the integrity of the manual is maintained and this copyright notice is reproduced. Other than as permitted above, you may not reproduce or transmit any part of this document, electronically or mechanically without the prior written permission of Oxford Instruments NanoScience.

Oxford Instruments' policy is one of continued improvement. The Company reserves the right to alter without notice the specification, design or conditions of supply of any of its products or services. Although every effort has been made to ensure that the information in this manual is accurate and up to date, errors may occur. Oxford Instruments NanoScience shall have no liability arising from the use of or reliance by any party on the contents of this manual and, to the fullest extent permitted by law, excludes all liability for loss or damages howsoever caused.

The Oxford Instruments Logo, Heliox and Kelvinox are trademarks of Oxford Instruments plc or its subsidiaries. The use of our trademarks is strictly controlled and monitored and any unauthorised use is forbidden.

**LabVIEW** is a registered trademark of the National Instruments Corporation in the United States and/or other countries

# 1 Introduction and System Requirements

The Oxford Instruments LabVIEW System Control Software provides control and monitoring of the Oxford Instruments range of superconducting magnets and ultra-low temperature systems (He<sup>3</sup> and dilution refrigerators).

The software consists of low level drivers for the different electronic instruments and the higher level applications that build upon the low level drivers to perform system specific tasks and routines.

This manual describes how to install, configure and use the software and has been written using PC rather than Macintosh terminology. Although most operations are the same for both platforms, you should note that control key operations involving the PC CTRL key should be performed on the Macintosh with the Apple ⌘ key. If additional support is required for the general operation or programming of LabVIEW, please contact National Instruments.

## 1.1 LabVIEW Versions

The release number of your software is given in the file readme.txt on the CD (in the directory DrvDisk1), as well as on the label of the CD. The LabVIEW versions used for the more recent Teslatron or OXSOF releases are listed below.

<b>Teslatron or OXSOF release</b>	<b>LabVIEW version</b>
Version <b>5.x.x</b> This software can be loaded into LabVIEW 5.x and 6.x Currently supported version (at the time of editing, version 5.0.7)	Written using LabVIEW 5.0
Version <b>3.9.1</b> This software can be loaded into LabVIEW 3.1, 4.x and 5.x Unfortunately, this version of the software is no longer under development. <b>Must run SetOptions.vi in Install.IIb</b>	Written using LabVIEW 3.1

Table 1- LabVIEW versions

## 1.2 Computer Specification

- SVGA graphics (800 × 600 pixels @ 16/256 colours)
- 166 MHz Pentium II Processor running Windows 95 (or later)
- 32 megabytes RAM + virtual memory (at least 64Mbytes for Windows 2000)
- Minimum of 30 MB of free hard disk space
- CD Drive
- A mouse, if COM1 and COM2 are allocated for other purposes then a bus mouse is recommended

The OXSOFT or Teslatron Installer software has been written to CD using a PC. If another type of computer system is used eg Macintosh or Unix, then steps to read the CD initially will have to be taken by the operator.

## 1.3 GPIB

We currently support GPIB cards from National Instruments only. If you are using GPIB communication then it is important that you choose a GPIB card compatible with LabVIEW, the operating system you are using, and that LabVIEW itself is installed with the correct options. Please consult National Instruments or the LabVIEW user manuals for details if necessary (an AT-GPIB is also compatible with Oxford Instruments' ObjectBench software). Please ensure that the GPIB driver from National Instruments is installed, configured correctly and the computer operating system recognises the card.

## 1.4 Serial Ports

Communications with Oxford Instruments' instruments can also be performed over an RS232 serial link. The Oxford Instruments ISOBUS system allows many instruments to be connected to a single serial port with each instrument having a unique ISOBUS address (ISOBUS address is simply a number between 0 and 9). However, if you are using an AVS47 or AVS46 via a picobus cable (supplied with many Kelvinox systems) you will require an additional dedicated serial port for this instrument.

### 1.4.1 Serial Ports on a Macintosh

There are two ports on a standard Macintosh to which the ISOBUS may be attached: the Modem Port and the Printer Port. Within LabVIEW (in particular the setup dialogs for each of the instruments) the :

Modem Port is equivalent to Com 1 on a PC

Printer Port is equivalent to Com 2 on a PC

An adapter lead is required to link the mini-DIN connector on the Macintosh to the 25 way D connector on the ISOBUS. This should be supplied with the ISOBUS cable. Note that the ISOBUS cable itself is a modified version of the ISOBUS cable supplied with PC systems in order to make it level compatible with the serial ports on the Macintosh. Older ISOBUS cables will not work with the Macintosh.

## 2 Installing the Software

### 2.1 PC Installation

If the target computer is a PC then the following procedure can be performed using the VI PCInstall.VI in the LabVIEW file Install.LLB in the directory DrvDisk1. Please follow these steps to install the software.

1. Start LabVIEW.
2. Open a VI (Virtual Instrument) : File | Open – a dialog box should appear.
3. Select "CD drive"\Tesl..." \DrvDisk1\Install.llb\PCInstall.vi. where ... is the software version number (please use the most recent version).
4. The following window will appear.

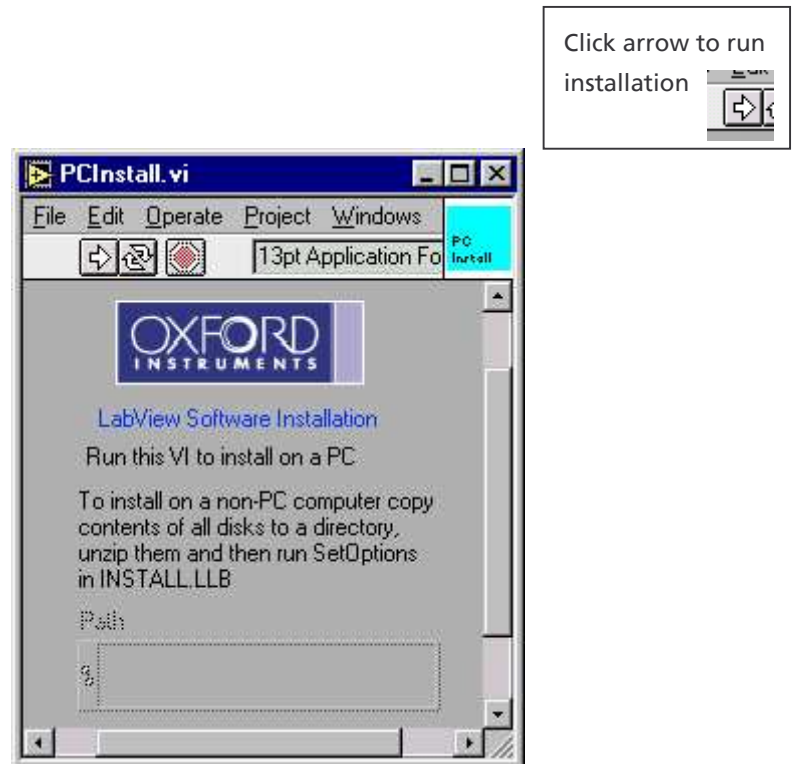

5. Run the software by using the mouse to press/select the arrow (indicated above)
6. A dialog will appear asking you to select a location to install the software. Please select a new directory on the computer hard drive.
7. Another dialog will appear asking which components of the software you would like to install. Please select the components relevant to your system (not all components are included with all installations)
8. The software will now copy files from the CD drive to your computer hard drive – these are zip files.

9. Following this, a window will appear to extract the zip files. Once the files have been unzipped a message will be shown saying "Close this window and continue with the installation". Please close the window.
10. Then select "Continue" on the dialog displaying the message "Press continue when unzipping has finished"
11. A readme dialog will now appear. Press OK
12. Finally, at the end, the software will be mass compiled to the version of LabVIEW you are using. This compiling operation will make the software execute more efficiently. Once the compiling has started, please be patient until the process has completed and a menu dialog is presented to you. At this point, the installation is complete and the user can setup the instruments and system software as required.

## **2.2 Manual Installation**

The software is distributed as a set of LabVIEW library files (extension LLB) which have been compressed using PKZIP, combined with other small initialization/documentation files which are un-compressed. Installation involves the following:

- a) Copying all the zip files from the CD into a new single directory on the computer (this can also be done from floppy disk or the World Wide Web).
- b) Uncompress each zip file and extract the contents to the same directory as the zip file. This will ensure that all the software stays in the same directory.
- c) For older versions of the software that are no longer supported (version 3.9.1 or older), please run SetOptions.vi in Install.llb. This is not necessary for later versions.
- d) If the software has been copied from a CD, please ensure that the setup and initialization files (\*.ini or \*.dat) are not "Read Only" files.

If you are re-installing the software, you should retain the old setup information by installing the updated software in a new directory and then copying your old setup files to this new directory. The setup files are small initialization files which have extension .DAT or .INI (eg tesltron.ini, kelvinox.ini, heliox.ini ... etc.)

If you are experiencing problems with the installation routine described in section 2.1, this manual installation can be used instead.

## **2.3 Macintosh and Unix Installation**

For Macintosh and Unix operating systems, the easiest way to perform the installation is to perform the manual installation described above. Please ensure that you have setup files representative of your system.

## **2.4 Post Installation**

When first using the installed software you will probably be asked to save changes when closing VIs. This is due to the version of LabVIEW or the computer platform you are using is not the same as that used by Oxford Instruments to write the software. You should answer affirmatively as this will save time when the software is next loaded and the code will execute more efficiently.

After installation you should keep the original installation disks or CD in a safe place, away from magnetic fields. When using floppy disks please write-protect each disk to prevent accidental overwriting of the software.

### 3 How to Start the Software

Start LabVIEW and run the virtual instrument (VI) called OIMenu.VI in the LabVIEW library file OIMENU.LLB. This allows access to all the Oxford Instruments software drivers installed on the computer. The menu allows the operator to setup the instruments communication parameters, launch the instrument drivers, execute system control software (where applicable) and start monitoring software to follow trends e.g. helium usage.

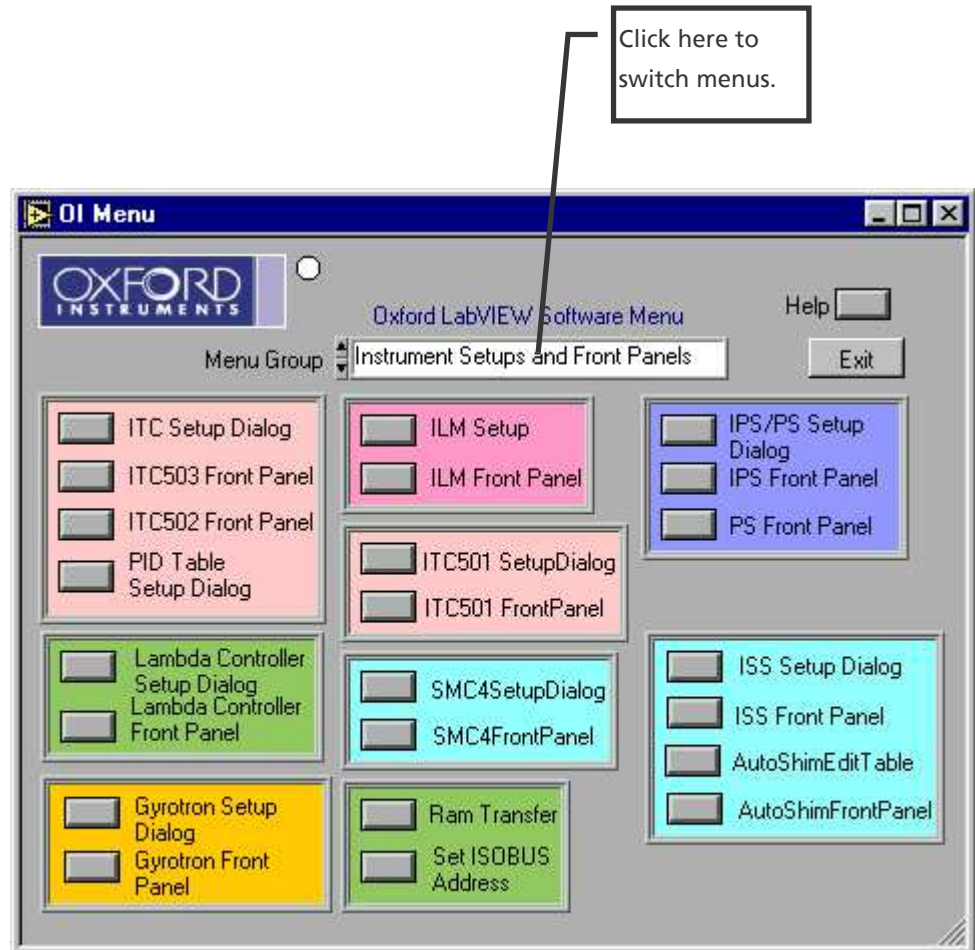

Figure 1 OIMENU.VI (oimenu.llb), the menu entry point to all other VI's

**Note :** Context sensitive help is available by use of CTRL-H (or ⌘ -H on a Mac) to open the help window which will display help on the control covered by the mouse pointer.

**Note** LabVIEW allows the user to stop a VI unconditionally<sup>1</sup> i.e. immediately by clicking on a stop symbol, or typing ctrl-. (control + period). This should be avoided in general, since it bypasses the normal program flow. Another useful key combination is ctrl-m which switches to edit mode. This may be necessary occasionally to obtain a menu bar. As a last resort, VIs that are not responding can be terminated by using the VI window menu at the top-left of the window (type alt-spacebar). Choose Switch to... and then End task. This will cause LabVIEW to exit.

With LabVIEW in edit mode, it is easy to make small inadvertent changes to a VI. A button or LED can be moved slightly for example. If this happens, LabVIEW will then ask if you want to save the VI when you try either to close it or to exit from LabVIEW. Unless the changes were deliberate, you should say No, and the changes will have no permanent effect. Sometimes your installation choices will force recompilation of VIs and you will be asked to save them even though you have not made any changes. In this case, you should save the VIs to avoid being asked the question.

It should be noted that any programming modifications to the standard drivers supplied by Oxford Instruments will not be supported (other than saving the vi's to the version of LabVIEW the customer is using).

---

<sup>1</sup> Note that this will not work if the VI is being called by a higher level VI – you must stop the highest level VI of the hierarchy.

## 4 Configuring the Instruments

Each instrument requires configuration within the software before the drivers can be used. The configuration includes the instrument remote communication parameters, a device name and type, along with possible system control parameters. This information is entered using the instrument specific setup dialog which is accessible via OIMenu.VI in OIMENU.LLB eg IPS/PS Setup Dialog for IPS/PS (PSSetupDialog.vi), or ITC Setup Dialog for an ITC (ITCSetupDialog.vi).

The setup information is stored in initialization files (\*.ini) eg tesltron.ini, igh.ini, kelvinox.ini ... etc. These should be edited using the Setup Dialogs for each instrument that can be launched from the OIMenu.vi. **It is not recommended to edit these files by hand as the text is not always easy to interpret.**

For each of the instruments follow the instructions given in section 4.3.

### 4.1 Communication Principles

To remote control/monitor Oxford Instruments electronic devices eg ITC, IPS, ILM ... there are some simple steps that must be followed.

- 1) Decide on the method of communication for the instrument eg RS232, GPIB, ISOBUS or GATEWAY and use the appropriate cabling.
- 2) Find or assign an address to the instrument in question (ie ISOBUS or GPIB addresses).
- 3) Enter the communication parameters into the software on the PC for the instrument in question.
- 4) Start the software driver for the instrument.

There are four methods of communicating to Oxford Instruments electronics : RS232, ISOBUS, GPIB, and GATEWAY.

RS232 communication is also known as serial communication and requires a single cable between the COM port of your computer and the instrument. For this method of communication, you only need identify the COM port on your computer.

ISOBUS is similar to RS232 and uses a unique ISOBUS cable made by Oxford Instruments. This ISOBUS cable allows a single COM port on the computer to be connected to multiple Oxford Instruments electronic devices in a daisy chain manner. One adapter (master) connects to the computer COM port and the other adapters (slaves) connect to the back of the electronic devices (RS232 connector). Each instrument has an ISOBUS address that is stored in the instrument memory and this ISOBUS address must be unique to each instrument connected to the ISOBUS cable. Communication to each device is then achieved by knowing the ISOBUS address of each instrument in question and the computer COM port the master plug is connected to.

GPIB communication is a well known method of controlling hardware. This requires a GPIB card (we only support GPIB cards from National Instruments) to be installed in a computer (with the necessary driver software installed), a GPIB cable and the GPIB interface to be fitted to the electronics in question. One end of the GPIB cable is connected to the GPIB card of the computer and the other to the back of the device. For multiple control of devices, another cable can then be connected in a daisy chain manner to another device. For this method of communication, you require the GPIB address of each instrument.

GATEWAY communication to devices is a combination of GPIB and ISOBUS technology. The computer is connected via GPIB (described above) to an instrument (known as the GATEWAY instrument). A small adapter (called a GATEWAY adapter) is then connected to the RS232 port of the GATEWAY instrument. The ISOBUS cable master adapter subsequently connects to this GATEWAY adapter and the other slave connectors of the ISOBUS cable connected to other instruments RS232 connectors (on the back of each instrument). With GATEWAY devices, the command is sent to the GATEWAY instrument via GPIB. However, the command is then relayed to the other instruments on the ISOBUS cable. For this method of communication you require the GPIB address of the GATEWAY instrument and the ISOBUS address of the instrument connected to ISOBUS cable.

Examples of these communication methods are shown on the next page.

**RS232 Communication**

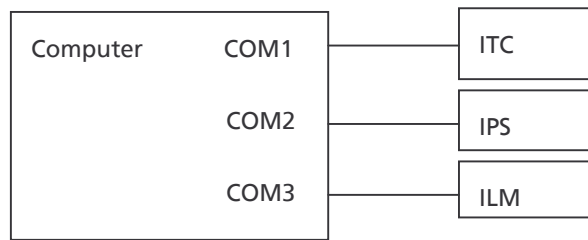

**ISOBUS Communication**

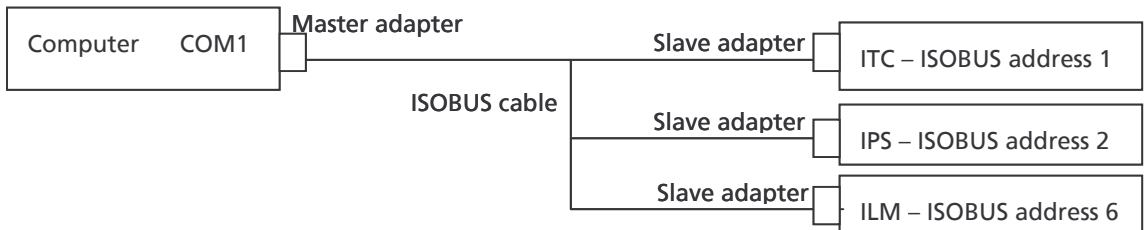

**GPIB Communication**

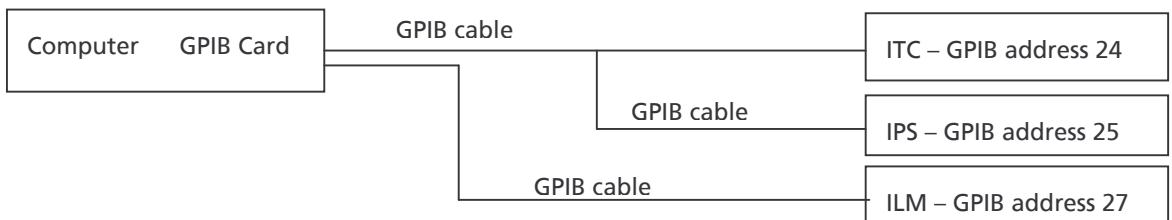

**GATEWAY Communication**

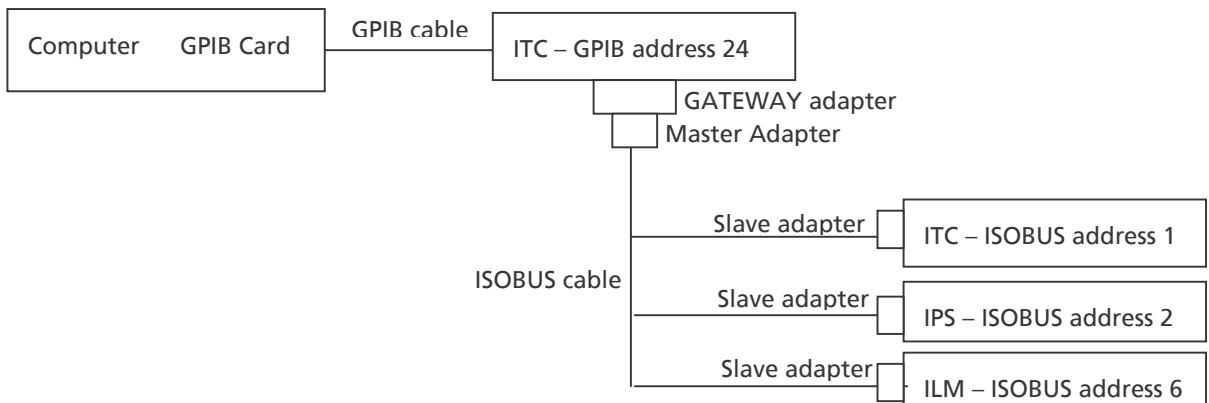

## 4.2 Communications Parameters

The type of communication link must be specified, and in the case of multi-instrument buses eg ISOBUS or GPIB, uniquely identify all instruments that are sharing the link. With version 5.x.x of the Oxford LabVIEW drivers, it is possible to mix the communication method between RS232, ISOBUS, GPIB and GATEWAY as the operator requires. With older versions of the Oxford Instrument drivers, your choice of GPIB or ISOBUS libraries at installation time selects the primary link from the computer to the instruments and the bus types can not be mixed eg ISOBUS (not GPIB) or GPIB (not ISOBUS).

To uniquely identify each instrument the software must know how and where to communicate with the instrument in question. This requires two steps.

- 1) The first step is to try and identify or set the address of the instrument. The two addresses in question are called the ISOBUS address and the GPIB address. The ISOBUS address can only be set using software (using Set ISOBUS address described in section 4.2.1). The GPIB address can only be set by entering the Test procedures for the instrument in question (please consult the instrument manual). Please select unique ISOBUS or GPIB addresses for each instrument (instruments with the same address will result in corrupt communication and data errors). This affects the address if the instrument internally and has no reference to the computer software.
- 2) Alternatively there is a tool which searches for instruments connected to your PC. Using LabVIEW, open and run the VI called "Search for Instruments.vi" in Instrum.IIb. Select the method of communication and search for instruments. This small utility will report the addresses of any device connected to the PC. If "Device conflict" appears, it implies that there are two instruments connected that have the same address. The address of one of the devices should be altered in this case. Please take note of the addresses of the instruments detected as you will require the information for the setup dialogs of the instruments.
- 3) Once the addresses of the instruments are known, the software communication parameters within the computer LabVIEW software must be set to the same values as the instruments. These parameters are entered via the setup dialog VI's launched from the main OIMenu.vi. At this point this is simply a software configuration, and does not affect the instrument itself.

Table 2 lists the different interface configurations and the values of the different interface parameters for each. Non-zero addresses are examples only and can be any unique number. Table 3 indicates the default ISOBUS addresses for our instruments.

#### 4.2.1 To Set the ISOBUS address of an Instrument.

Each of Oxford Instruments electronic devices eg IPS, ITC, ILM.... have an internal ISOBUS address (similar to a GPIB address). The ISOBUS address is simply a number between 1 and 9 and must be unique to each device ie to each IPS, ITC, ILM etc. It can only be set using software commands. In order to use a computer to control many devices from a single COM/RS232/Serial port of a computer, you can use an ISOBUS cable along with the ISOBUS addresses of all the instruments.

To assign an ISOBUS address to a device, please select "Set ISOBUS address" from the OIMenu. This will open a LabVIEW VI called SetISOBUSAddress.VI. Enter the required values for the communication parameters. Select OK and follow the instructions (Note: please ensure that no other instruments connected to the ISOBUS cable are turned on, otherwise the software will attempt to set all the instruments connected to the ISOBUS cable to the same ISOBUS address).



<b>Instrument Interface</b>	<b>COM Port</b>	<b>ISOBUS</b>	<b>GPIB</b>
Direct serial link to computer. Communication : <b>RS232</b>	No of com port used.	-1	N/A
ISOBUS directly to computer. Communication : <b>ISOBUS</b>	No of com port used.	Enter the ISOBUS address of the instrument.	N/A
ISOBUS which is connected via a gateway instrument Communication : <b>GATEWAY</b>	N/A	Enter the ISOBUS address of the instrument	GPIB address of the gateway instrument
GPIB only. Communication : <b>GPIB</b>	N/A	0 There is no need to set the ISOBUS address in the instrument to 0 however as the firmware will only respond to ISOBUS 0 when interfaced via GPIB	GPIB address of instrument
Instrument is a gateway instrument. (GPIB to computer and Gateway unit to ISOBUS) Communication : <b>GPIB</b>	N/A	0 There is no need to set the ISOBUS address in the instrument to 0 however as the firmware will only respond to ISOBUS 0 when interfaced via GPIB	GPIB address of instrument
AVS connected directly using PICOBUS to PC com port	No of COM port used	N/A	
AVS connected using an AVS47-IB	n/a. For Picobus address use the default of 1	GPIB address of instrument	

**Table 2 Possible interface configurations and the associated communication to be entered in Setup Dialog VI's. N/A stands for "Not applicable" in which case the value is not used .**

<b>Instrument</b>	<b>Address</b>
ITC502/503	1
PS120/IPS120	2
Lambda controller	3
SMC4	4
IGH	5
ILM200	6
ISS10	7

**Table 3 Default ISOBUS addresses**

### **4.3 Step by Step instruction on Configuring and Running an Instrument VI**

This information is relevant for any of the following instruments: IPS, PS, ITC501, ITC502, ITC503, ITC601, ILM, ISS, SMC4, SMC1, Lambda Controller, Gyrotron Controller, IGH, AST Controller.

### **4.3.1 Open the Instrument Setup Dialog VI**

Open the appropriate instrument setup dialog from OIMENU.VI. For example, for an IPS or PS open IPS/PS Setup Dialog (PSSetupDialog.VI) as shown in Figure 1. The Setup dialog for the power supply (IPS) is shown below.

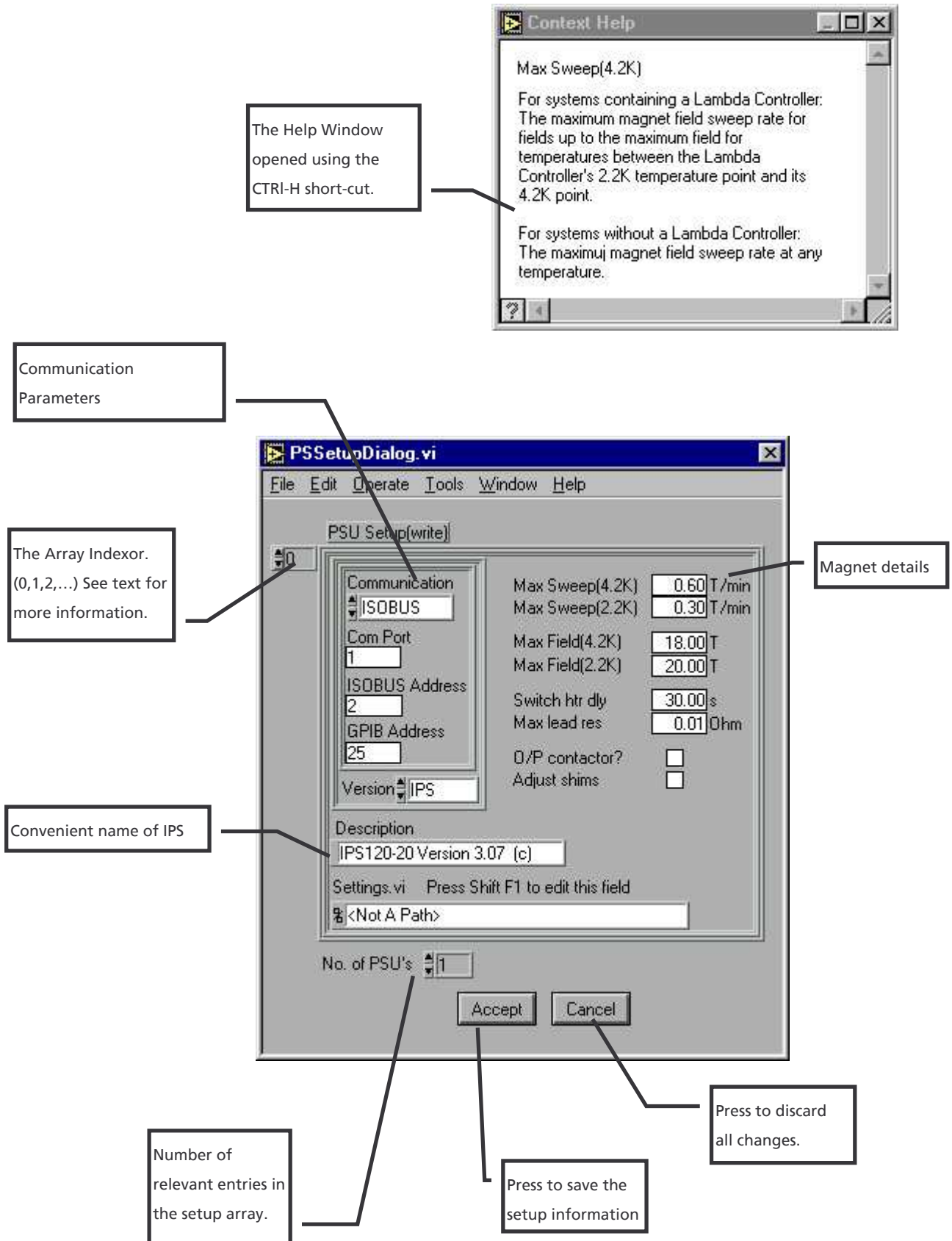

**Figure 2** The PSSetupDialog.VI and the Help Window showing help on the item Max Field (4.2 K) obtained by using the CTRL-H short-cut and moving the mouse over the Max field (4.2 K) control.

The main element of any SetupDialog VI is the Setup Control in which information for an instrument is entered. Having entered the information for the instrument in the Setup Control press the Accept button to save the settings.

In figure 2 there are two extra elements: the Indexor and control labelled "No. of PSU's". For the cases of ITC's, IPS/PS's and ILM's one may need to enter information for more than 1 instrument, e.g. the Heliox system can use 2 ITC's. In such cases enter the information for the first ITC or IPS/PS into the Setup Control with the Indexor set to 0 and then change the Indexor to 1 to enter the information for the 2nd instrument; finally set the No. of PSU's control to 2 before pressing the Accept button to save the changes to file.

### **4.3.2 Enter values for the Communication Parameters**

Using the information in section 4.2 you need to decide on relevant values for Communication, COM port (if applicable), ISOBUS address, and GPIB Address (if applicable) and then enter them into the controls shown in Figure 2. e.g. an IPS acting as a GPIB gateway at GPIB address 25 would have values COM port (not applicable), ISOBUS address(0) and GPIB address(25).

### **4.3.3 Enter values for the remainder of the Setup**

Using the on-line help to guide you (CTRL H), enter values for the other parameters in the Setup control (system parameters).

### **4.3.4 Save the Setup**

When you are happy with the setup parameters use the Accept button to save the settings. Close the SetupDialog.VI window using File | Close command.

### **4.3.5 Open the Instrument Front Panel VI**

Once the communication parameters have been entered for the instruments, press the relevant button on OIMENU to open the FrontPanel VI for the instrument. e.g. for an IPS press the IPS FrontPanel button. If the communication parameters are correct, the VI will put the instrument into remote control and live data will be displayed on the software.

## **4.4 ITC PID Table Setup**

Certain applications, such as Heliox and Teslatron, can set predefined PID parameters to an ITC when changing the set point temperature. For such applications you need to enter sets of PID parameters for different temperatures using the PID SetupDialog.VI.

Note that the PID table is not used by the ITC front panel (software). When a temperature is set from here, the PID values of the instrument are unaffected, except in the case of an ITC503 in Auto PID mode when appropriate values will be set from the instruments internal PID table in the usual way.

## 5 Graphing, Logging and Log Analysis

Values of signals from temperature controllers, level meters and power supplies can be monitored and logged using GeneralGraph.VI in Graphs.LLB. Before starting this VI for the first time configuration data should be entered using GeneralMonitorSetupDialog.VI as described in section 5.1. On-line help for the different controls on the VI is available in the Help window (Keyboard : Ctrl H)

Log files produced by the General Graph facility and other applications can be analysed using the AnalyseData.VI in ANALYSIS.LLB. On-line help is available on the Help window and via the Help button.

### 5.1 How to use GeneralMonitorSetupDialog.VI

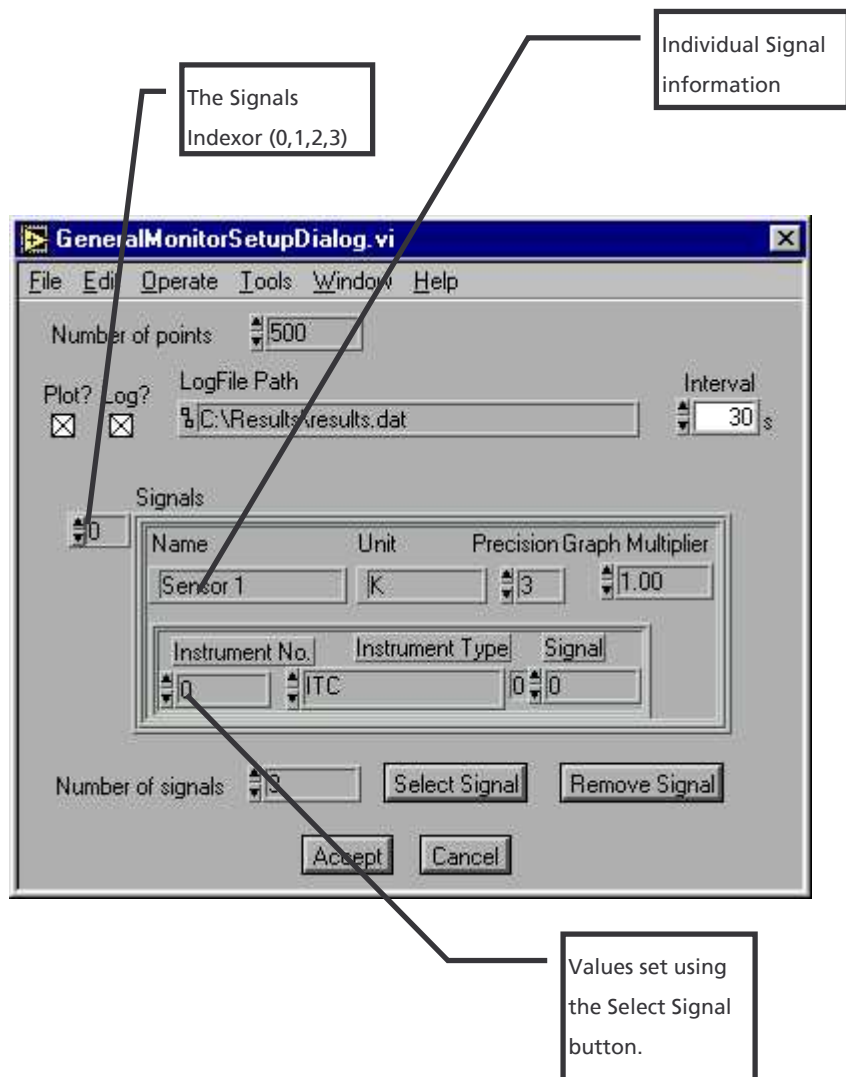

**Figure 3 GeneralMonitorSetupDialog.VI in GRAPHS.LLB. Use this VI to specify which signals to be plotted by GeneralGraph.VI**

On-line help for the different controls on the VI is available in the Help window.

The control labelled Signals is a LabVIEW array of individual signal information (it's value ranges from 0 to n-1 where n is the number of signals). To view and edit information for a signal change the value of the Indexor; note that the first signal information is shown when the Indexor is 0.

### **5.1.1 Adding a Signal**

If the number of signals already defined is n then set the Indexor to n and change the Number of Signals control to n+1. Press the Select Signal button which will open the SelectSignal.VI. Follow the instructions on SelectSignal.VI to specify the instruments and signal required. On returning from SelectSignal some controls in the Signals control will have been changed. You must now edit the controls Name, Unit, Precision, GraphMultiplier to complete the signal specification.

### **5.1.2 Removing a signal**

Change the Signal Indexor until the Signals control shows the information for the signal to be removed. Press the Remove signal button. After that decrease the Num of Signals control by 1.

## 6 Programming with the VIs

The real strength of the software is the way that its functionality has been packaged into modules that can be called from LabVIEW programs developed by the user. Third party instrument drivers are available, which, together with the drivers supplied by Oxford Instruments, allow creation of custom applications for performing specific experiments.

The VIs are organised into:

- Applications e.g. Teslatron, Kelvinox, Heliox, Graphs
- Instrument front panels - e.g. ILMAPPS, PSAPPS
- Instrument drivers - e.g. ILMSUBS, PSSUBS
- Interface/communication drivers - BUS.LLB
- Utility VIs

See example VI's in EXAMPLES.LLB for help on how to use the low level drivers. The best way to understand the higher level software is to study the VIs themselves.

## 7 Troubleshooting

This section lists some common problems and their solutions. If these do not enable you to resolve your difficulties, please contact Oxford Instruments.

### VI 'Hangs'

There is probably a communications problem due to the cable or communication parameters entered for the instrument – see section 7.1. If the problem does not appear to be communications-related, try re-installing the software.

### VI appears to be running but does not respond

First ensure that it *is* running, by pulling down the Run menu. If the Run command is available as an option (that is, not greyed-out) then the VI is not running. If it is running then it is possible that a sub-VI has been stopped or closed in an abnormal manner. Try reloading this sub-VI to see if it is still running and then exit it using front panel buttons rather than menu options. See also section 7.1.

### Software slow to respond

The Kelvinox software in particular, but all LabVIEW software to some extent, requires a fast processor and a lot of memory to run at a reasonable speed. Even with a well specified machine however, you may find that the Kelvinox VIs are slow to respond. This is simply a consequence of the size and complexity of the software. Apart from increasing LabVIEW's memory allocation (LabVIEW for Mac and LabVIEW for Windows 3.0.1 and earlier) there is little that can be done apart from upgrading the computer. Do not press buttons repeatedly while waiting for a response – their action is latched which means a single press is always sufficient.

### Unable to close a VI

Some VIs are dialog boxes that are launched from a higher level VI, and automatically disappear once they have finished executing. If you load these directly, you may not be able to close them from the menu. To get rid of them, first switch to edit mode by pressing CTRL-M and you will then be able to close them in the normal way.

### ISOBUS timeouts

If you press a button on a real instrument front panel while Teslatron is trying to communicate with it, the computer will beep. After a few seconds, if you do not release the button, a dialog box is shown. Release the button and press Continue.

### Intermittent communications errors

This can happen if the com port has been incorrectly initialised, in particular if only one stop bit is being used. This can manifest itself either as timeouts even though the instruments are not being interfered with, or Command Rejected errors. All the higher level VIs automatically perform correct initialisation of the com port, but if you load and run a lower level VI directly, or if you have written your own, then it is possible to get into this situation. You must exit and re-start LabVIEW in order to reinitialise the port.

## 7.1 Isolating communications problems

This section gives a step-by step guide to isolating and fixing some of the more common communications problems.

1. If the VI is a high level one, such as the Teslatron System Manager, proceed from step 3 with each of the component instruments (temperature controller, magnet power supply etc.).
2. If the VI is the Kelvinox Front Panel, particular care must be taken, since the optional AVS requires a special initialisation of its serial port. This can occur even if you do not have an AVS when the appropriate option is not deselected in the setup. Make sure that com ports are correctly assigned to AVS and IGH.
3. Disconnect all instruments from their communications lines, except for the one under scrutiny. In the case of Gateway networks however, you must always have the Gateway instrument switched on in order to talk to a slave instrument.
4. Switch the target (and Gateway) instrument off briefly, and then on again. Make a note of GPIB and ISOBUS addresses if they appear during startup.
5. Load and run the instrument front panel.
6. If the instrument front panel runs, then move on to the next instrument and repeat from step 3.
7. If the instrument front panel does not run, quit and restart LabVIEW and Windows. This is to ensure that any com ports initialised incorrectly are cleared before investigating further.

8. **(Instrument Front Panel does not run, AVS instrument)**

Load the AVSSetupDialog VI. Check that the com port and Picobus address are correct. The Picobus address will nearly always be 1. Try increasing the Picobus Delay. Check cabling and plugs. Ensure the instrument is correctly configured (in hardware) for the interface type – Picobus, TTL Picobus or GPIB. This is explained in the AVS manual.

Load the VI called BusCommand.VI from the BUS.LLB library. This provides a quick and easy method of checking a particular instrument with different configurations.

1. Enter the communications parameters for the instrument directly into the left-hand panel on the VI, and enter a capital 'V' into the command section. Run the VI.
2. If the VI runs properly, a version message from the instrument will appear in the Reply field. This indicates that the parameters are correct and that the instrument is correctly connected and set up.
3. If you have a simple ISOBUS system, enter an ISOBUS address of -1, this will cause the command to be sent out as if without any addressing prefix. If the instrument responds, the problem is with addressing.

4. If you have a Gateway instrument then use an ISOBUS address of 0. Disconnect the Gateway Adapter from the instrument so that the computer is only talking to the Gateway instrument. Once you establish communication to the Gateway instrument you will have to use SetISOBUSAddress.VI to set the ISOBUS address of the other instruments to non-zero values before attempting to talk to them using BusCommand.VI.
5. If you experience problems talking through the Gateway adapter you can attempt to talk to each instrument individually using its' serial ports and a 25-way pin to pin ribbon cable to a serial port on the computer.
6. If you are using GPIB to talk to the instrument, check you are using the right GPIB address.
7. Try swapping cables (GPIB systems) or serial plugs (ISOBUS/Gateway systems) on the target instrument and re-running the BusCommand VI. If you can make the instrument respond in this way then the problem is clearly with the cabling.
8. Load and run the SetupDialog for the instrument. Check the settings correspond to those in the BusCommand VI. Adjust the setup if necessary.
9. If all the individual instrument Front Panels work, but a higher level VI does not, then make sure that the instruments have unique ISOBUS and GPIB addresses.
10. As a last resort, try re-installing the software, before contacting Oxford Instruments.

## **7.2 GPIB Problems**

The majority of GPIB problems occur due to incorrect set-up of the driver in the computer.

We recommend the use of AT-GPIB boards rather than the older PC-II as the latter have problems on fast Pentium based computers.

Always use the latest version of the driver. If any diagnostic tests are provided with the driver software for the board then use them.

Oxford Instruments' VIs do not use DMA transfer or interrupt level processing. It is recommended that DMA transfer is turned off and the IRQ setting set to 'None'.

On a Macintosh ensure that 'Extensions' have been turned on.

## **8 Teslatron or OXSOF (B/T Environment Software)**

### **8.1 Introduction**

Teslatron or OXSOF is a suite of software used for controlling a superconducting magnet and variable temperature insert providing:

- Automatic setting of magnet field strength including operation of superconducting switches.
- Automatic setting of shim currents for high field homogeneity magnets.
- Automatic operation of a Lambda Fridge to allow magnet operation at 2.2 K for extra high fields.
- System protection from cryogenic level or Lambda Fridge failure.
- Control of variable temperature inserts including automatic setting of temperature controller PIDs.

The modular design of the LabVIEW software allows the user to easily customise the software for their particular experiments.

The major components are as follows.

#### **8.1.1 Teslatron or B/T System Manager**

This VI is the main entry point into the Teslatron software. As well as providing access to the other components it also provides direct control and monitoring of a single magnet and insert temperature controller.

#### **8.1.2 Sequencer**

This VI allows the user to specify a sequence of magnet strengths and insert temperature for a particular experiment.

#### **8.1.3 Fridge**

The Fridge VI automatically adjusts the Lambda Fridge valve to attempt to maintain the magnet temperature below the user specifiable target temperature.

#### **8.1.4 Interlocks**

The temperature of the magnet as well as the helium level is monitored and if required the magnet current reduced to within allowed limits.

#### **8.1.5 Self Test**

The Self Test checks that the interface to all the equipment works and that the magnet lead resistance is OK. It is recommended that you run the Self Test before any other software as it may interfere with software operation.

## **8.2 Configuring the Software**

First configure the different instruments as described previously.

Access to the setup dialogs to be used to enter Teslatron or B/T configuration data is provided via the OIMENU.VI in OIMENU.LLB.

### **8.2.1 Teslatron or B/T SetupDialog**

This contains the basic information needed to run Teslatron.

Note that On-line help is available on the Help window.

### **8.2.2 Fridge Setup Dialog**

Information required if a Lambda Fridge is present on the system.

The Fridge VI has two pressures it tries to maintain, the Upper Pressure for when the magnet temperature is above the target and the Lower Pressure for when the magnet is at or below the target temperature.

The Deadband prevents continual hunting of the valve. If the actual pressure is within the Deadband of the required pressure no adjustment of the valve is made.

## **8.3 How to Use the Software**

Use OIMENU.VI to open B/T System Manager. As selected in the TeslatronSetupDialog.VI this VI will perform a self test, start the interlocks VI and the fridge VI.

Use CTRL-H and move the cursor over the element of the VI of interest to view the context sensitive on-line help.

## **8.4 How to Build Your Own Application**

The vi's SetDemo.vi in Tesltron.llb and RampDemo.vi in Ramp.llb are examples of applications which automate the use of Teslatron. With inclusion of your own measurement VI these can easily be customised into useful applications.; especially when combined with use of the General Logging VI described in section 5.

For advice on customising the software please contact Oxford Instruments.

## 9 Heliox

The Heliox suite of VIs provides a mimic front panel image of the system and lower level tools to run an Oxford Instruments Heliox system. For an explanation of the terminology used here, please consult the Heliox manual.

### 9.1 The Heliox panel

The Heliox Front Panel is opened via the Applications panel of OIMENU.VI in OIMENU.LLB. This panel provides access to all other features of the Heliox software and must be running at all times if automatic recondensation is required.

### 9.2 The Recondense VI

The recondensation process can be initiated either by the user using the Condense button on the Heliox Front Panel.vi, or automatically according to conditions entered in the Setup dialogue. The objective of the condensation process is to liquefy as much as possible of the  $^3\text{He}$  charge.

The basic procedure consists of heating the sorb and then waiting for the  $^3\text{He}$  pot temperature to drop below a specified threshold level. This is then repeated with a different set of  $^3\text{He}$  target temperature and 1 K pot needle valve. The purpose of the second part is to allow the 1 K pot to be run in single shot mode thus creating lower temperatures. Following condensation the sorb is then cooled rapidly to a value at which it can be used to control the pot temperature.

In a non-fully motorised system the settings of the needle valves must be performed manually.

In Figure 4, a schematic representation of sorb and pot temperatures is given over the time taken to recondense the  $^3\text{He}$ . The temperatures T(1) and T(2) are threshold values defined in the Heliox setup and discussed in more detail in that section.

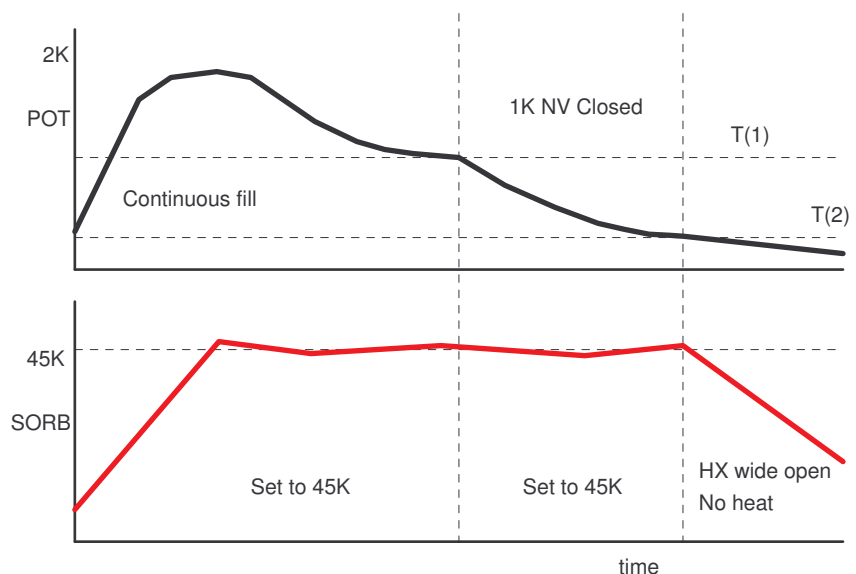

Figure 4 - Sorb and pot temperatures during condensation

### **9.3 The Heliox Setup**

Most of the functionality of the Heliox software comes from knowledge of the physical locations of sensors and needle valves. This knowledge is provided through the setup VI.

First setup the ITC using the ITCSetupDialog which is described elsewhere. Subsequently use the Heliox Setup Dialog via the OIMENU.VI to enter system parameters for the Heliox itself.

The setup parameters are divided into groups according to their function. On-line help is available by hitting CTRL-H. The Help window will provide additional information regarding the input field closest to the mouse pointer.

## 10 The Kelvinox software

The Kelvinox software automates operation of Oxford Instruments Kelvinox dilution refrigerators using the IGH gas handling system and IDR<sup>PS</sup> power supply. This section refers only to software operations and assumes familiarity with cryogenic terminology and dilution fridge operation.

Kelvinox provides:

- Complete automation of the fridge, allowing:
- Initial cool down from room temperature
- 1K pot filling and monitoring
- Condensing of the mixture
- Circulation of the mixture
- Warm up and safe removal of mixture to the dump
- Simple exchange of TLM probes( even during circulation)
- Make safe feature to pump mixture to dump
- Control and monitoring of pressures, valves, temperature and heaters
- Comprehensive ULT thermometry and temperature control

### 10.1 Software organisation

The software consists of a collection of sequences which automate the most common dilution refrigerator operations. Sequences can be accessed either from the Kelvinox Front Panel, or directly, by loading and running the relevant VI.

Sequences all share a number of common features. There are two buttons on the front panel, Skip and Abort. The first of these causes the sequence to proceed immediately to the next step of the sequence without waiting for the usual conditions. The sequence will then proceed normally. The Abort button will stop a sequence completely after you have confirmed the action. If you use it during a sub-sequence, then the top-level sequence is also stopped, although other VIs will continue to run. You should always be careful that you are not leaving the system in an unsafe state after aborting a sequence.

The VIs are divided into five libraries. The high level VIs most likely to be used regularly are kept in the KELVFNLS.LLB library. The main sequences are stored in the KELVSEQ.LLB and KELVSEQ2.LLB libraries. The KELVUTIL.LLB libraries contains utility VIs for less common fridge operations. The KELVSUBS.LLB contains lower level VIs which are not generally used directly but which are required by the higher level VIs.

### 10.2 Usage notes

The Kelvinox software often involves simultaneous display of several different VIs and the screen can quickly become very cluttered. It is therefore strongly recommended that you run your computer monitor in the highest resolution mode available.

The size of this software suite, and the fact that many VIs can be running simultaneously means that LabVIEW performance can suffer. Response to mouse actions can be slow, so allow a little time before assuming that a command has been ignored.

### 10.3 The Kelvinox front panel

The Kelvinox front panel is displayed in Figure 5. Depending on your system configuration, its appearance can vary. The Front Panel displays the primary system variables, and allows push-button access to a range of sequences and utilities. Sequences can also be loaded and run separately as standalone VIs, but not while the Front Panel is running. The Front Panel can take a long time to load because of the large number of sub-VIs that also have to be loaded.

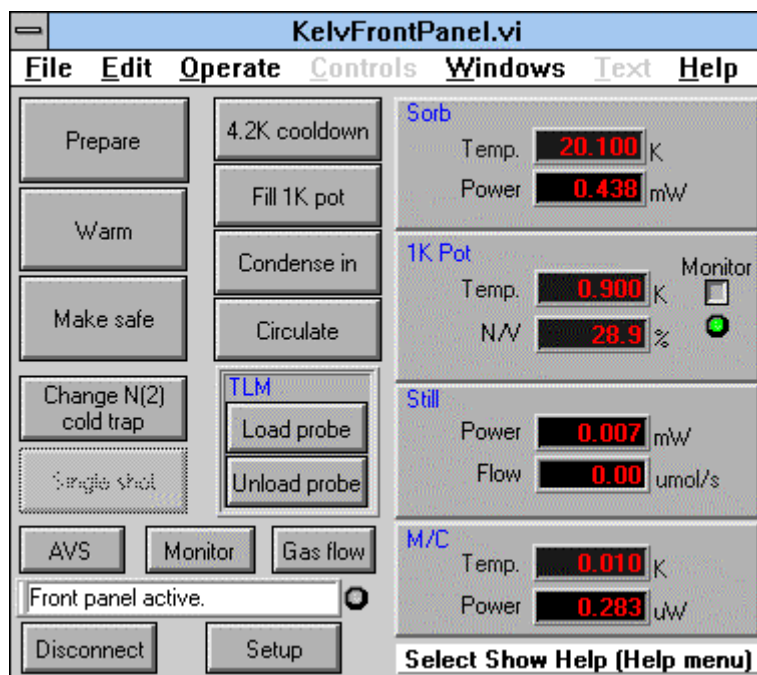

Figure 5 - kelvinox\kelvpnl\KelvFrontPanel.vi

Running the Front Panel will cause the 1K Pot Monitor to start automatically. This VI is discussed in section 10.13. When you disconnect the Front Panel, the Monitor is also stopped, and will disappear (unless you have loaded it up separately). At startup, the temperature of the 1 K pot is compared with the empty limit defined in the 1 K pot setup. If the temperature is higher than this limit, then the monitor is initially disabled, otherwise it is enabled.

You can temporarily enable or disable the Monitor with the button in the 1 K pot panel. The nearby LED shows its actual status. Some sequences will override this setting. If you have disabled monitoring from the 1 K Pot section of the Setup, then you cannot enable it again without changing the Setup. Similarly, sequences will not be able to enable monitoring if you have disabled it from the Setup.

If you launch sequences or other VIs from the Front Panel you should always exit from these VIs in the approved manner. In the case of Sequences, this means waiting for them to finish; either normally, or by using the Skip or Abort buttons. In the case of other VIs launched from the Front Panel, it means pressing the Disconnect button. In normal use, you should always use the Disconnect button to stop the Front Panel.

The blinking light by the status bar indicates that the Front Panel is both running and active. Remember that the more VIs you have running, the slower will be the response of the system. The rate of blinking will give you some idea of the speed of response that you can expect. You should still be able to launch the Gas Flow VI (the IGH Front Panel) while sequences are running. You cannot Disconnect the Front Panel while *any* sub-VIs launched from the Front Panel are still running.

Note that you cannot directly load and run a sub-VI of the Front Panel (such as a sequence) while the Front Panel itself is running. You must launch it using the appropriate Front Panel button. Similarly, if you load and run a sub-VI while the Front Panel is *not* running, you will not be able to run the Front Panel until that sub-VI has stopped.

### 10.3.1 Sequences

When a sequence is launched, a dialog appears explaining the function of the sequence and asking you to confirm your choice. Note that this message will only appear when the sequences are run directly and not when they are used as a sub-sequence. This confirmation step is not shown on the sequence flow diagrams.

Run and Warm are the primary operational sequences, and are described in sections 10.4 and 10.4 respectively. The Run button is renamed Prepare on TLM systems, and the sequence is changed slightly to prepare for top-loading of a probe. The 4.2 K cooldown should be used when cooling the system from room temperature, before running to base temperature. Make Safe switches valves and powers to a safe configuration as described in section 10.8. Fill 1 K Pot, fills the 1 K pot with helium and sets a continuous fill flow rate (see section 10.5.1). Condense In and Circulate allow the two main sub-stages of running a fridge to be performed separately.

Change N(2) Cold Trap allows the mixture to be re-diverted through an alternative nitrogen cold trap.

**Note** Two special sequences are provided for TLM (Top Loading into Mixture) systems. These are Load Probe and Unload Probe discussed in sections 10.8 and 10.9 respectively.

The Single Shot sequence is not yet implemented.

### 10.3.2 Utilities

The AVS button launches an AVS control and monitoring utility described in section 10.12. This button is not shown if you have deselected the AVS option in the Kelvinox setup. The Monitor button launches the IGH Monitor described in section 10.17.

## 10.4 The 4.2 K cooldown sequence

The 4.2K cooldown sequence takes the fridge from room temperature to 4.2 K. It should be used directly after connection of pumping lines and assumes that all mixture is in the dump.

## 10.5 The Run-To-Base sequence

The RunToBase sequence takes the fridge from the 4.2 K state to circulation of mixture. It fills the 1 K pot, condenses in the mixture and starts mixture circulation.

### 10.5.1 The Fill Pot sequence

Fills the 1 K pot and sets the needle valve to an automatically determined continuous fill level. It also determines a needle valve position for a lower 1 K pot temperature.

### 10.5.2 The Condense sequence

Condensation is performed by gradually cracking open valve V12A while maintaining the pressure at G1. Because of the highly non-linear nature of the valve, quite large deviations from the set point will occur, and are not a cause for concern.

Adjustment continues until the valve has exceeded the displayed maximum setting and the displayed gauge is below the target pressure.

A refinement to this process is used in the case of systems with two interchangeable mixing chambers. If the smaller of the two is being used, it is necessary to reduce the amount of mixture used in circulation. During condensation, the pressure at G2 is continuously monitored. When it drops below the shutoff value defined in the Setup, valve V9 is closed in order to isolate the dump vessel from the circulation system.

### 10.5.3 The Circulate sequence

The Circulate sequence starts mixture circulation by gradually opening V6. If the sequence is being used to prepare a TLM system for probe loading, then V6 is closed again and V3 opened. Otherwise, the Roots pump and still power are turned on to start circulation.

## 10.6 The Warm Up sequence

The WarmUp sequence empties the 1 K pot, applies power to M/C and still and then pumps/pumps and flushes until the fridge is empty.

### 10.6.1 The Empty Pot sequence

This sequence empties the 1 K pot with alternate pumping and flushing operation using helium gas from the main bath. The empty condition is defined by parameters in the setup.

### 10.6.2 The Pump sequence

KelvPump.VI pumps the mixture out of the fridge into the dump.

It can be used either as part of a pump and flush sequence, or to empty the unit directly; this depends on the parameters in the Warm Up section of the Kelvinox Setup.

The primary operation is to open valve V6 slowly, using feedback from G2. After V6 has fully opened, the pressure P1 is monitored until it falls below the threshold defined in the Warmup parameters section of the setup.

### 10.6.3 The Flush sequence

The flush sequence admits warm mixture to the unit thus increasing the rate of warming.

## 10.7 The Change Cold Trap sequence

This VI changes the setting of which cold trap to use in subsequent sequences. It also isolates the unwanted cold trap and opens the new cold trap.

## 10.8 The Load Probe sequence

This VI ensures that the process of loading a TLM probe is carried out correctly.

The fridge is normally in a condensed state before the sequence is started. However, if you want to speed up the process of unloading and re-loading a probe you can do so with the fridge left circulating.

A simple graphing utility (KelvTLMPotWatch.vi) is called for the actual lowering of the probe beyond the pre-cool stage. This displays the current 1 K pot temperature against a rather arbitrary upper limit which is simply defined as the starting temperature plus 0.3 K. By watching the graph as you lower the probe, you can optimise the speed to load as fast as possible without overloading the pot. If you exceed the maximum temperature, the display will flash.

## 10.9 The Unload Probe sequence

This VI ensures that the process of unloading a TLM probe is carried out correctly. The fridge is normally left in a condensed state at the end of the sequence. However, if you want to speed up the process of unloading and re-loading a probe you can request that the fridge is left circulating.

## 10.10 Make Safe

Make Safe starts pumping the mixture into the dump. This VI can be useful if you are unsure about the settings of valves, or if there is excessive power entering the unit. It can be considered as a panic button.

After execution, mixture will start to be removed to the dump, although the speed with which this happens depends very much on the temperature of the unit.

You should not use this as a routine method for warming up the refrigerator.

Use this VI only when the fridge is running below 4.2 K.

## 10.11 The IGH monitor

IGHMonitor.vi in IGHMON.LLB graphs and logs the IGH. The behaviour of IGHMonitor is controlled using the IGHMonitorSetupDialog VI. Logged data can be viewed using the AnalyseData VI in Analysis.LLB.

## 10.12 The AVS monitor

AVSMonitor.vi in AVSMON.LLB graphs and logs the sensors readings of an AVS and provides access to the AVS Front Panel. Setpoints for a TS530 temperature controller can be sent using the AVSMonitor. Resistances can be converted to temperatures provided that the Sensors Calibration have been entered using the Sensors SetupDialog VI in SENSORS.LLB.

The behaviour of AVSMonitor is controlled using the AVSMonitorSetupDialog VI. Logged data can be viewed using the AnalyseData VI in Analysis.LLB

## 10.13 The 1 K Pot monitor

This VI monitors the 1 K pot and adjusts the 1 K Pot needle valve to keep the 1 K pot temperature below a certain value.

It operates almost independently of any other processes but can be enabled, disabled or stopped by other VIs.

The VI periodically checks the 1 K pot temperature and compares it with the T(Adjust) value (taken from the 1 K Pot setup and displayed on the Monitor). In the case of TLM systems, this adjustment threshold is increased by the Top Load Inc. parameter during the top-loading process, because of the load this puts on the pot.

If the temperature exceeds the threshold, then the Adjust light is lit, and the following process is carried out:

First the 1 K pot needle valve is closed completely for a period defined by the Delay parameter in the 1 K Pot setup.

The temperature is then compared with that before the valve was closed. If the temperature has risen or remained constant, then the pot is deemed to have been empty. It is filled for the Fill Time defined in the setup, and a new continuous fill setting calculated as the original valve position plus the Adjustment value from the setup.

If the temperature has fallen as a result of the needle valve being closed, then the pot must have been overflowing. In this case, the continuous fill setting is simply reduced by the Adjustment amount from the setup.

After this, further adjustment is disabled for five minutes to allow the 1 K pot to stabilise at the new setting.

## 10.14 The Quench Monitor

KelvQuechMonitor.VI prevents mixture loss in the case of very sudden warming of the dilution unit while circulating. This might happen if a superconducting magnet were to quench causing eddy-current heating.

The monitor operates independently of any other processes, except that it is terminated when the Front Panel is disconnected

## 10.15 The Kelvinox setup

The setup editor is KelvSetupDialog.vi in the KELVPNLS.LLB. Because of the complexity of the Kelvinox setup, most of the setup has been delegated to sub-sections which are accessed with buttons on this dialog. The values in this dialog either relate to the system as a whole or do not fit naturally into any of the sub-sections.

On-line help is available for this VI and all the sub-VIs. Press CTRL-H and a Help window will appear. Click back on the VI to make it the foreground window again. As you move the mouse pointer, help will be displayed for the nearest control. If the Help window does not seem to work, press either shift key to update the display. Press CTRL-H again to remove the Help window.

### 10.15.1 Valve adjustment

Some processes associated with running a dilution refrigerator involve adjustment of a valve while monitoring a pressure gauge. The four setup sub-VIs specify how this process is to be performed for different situations. All have in common a dark panel containing four values which relate to adjustment of the valve. The first value is an initial setting for the valve which will have been established as being close to but less than the value at which gas flow actually starts to occur. The second value is a time interval between adjustments of the valve. This should be comparable to the time delay between valve adjustment and gauge response so that further adjustment is not made until the effects of the previous one have been registered. The third parameter is an increment by which to adjust the valve every interval.

Finally, the maximum setting is a time saving measure. When the valve has been opened beyond this point, it is considered to be effectively fully opened and can be set immediately to 99.9 without having to increment it to this value. As with the initial setting, this number will thus depend on the mechanics of the valve in question.

### 10.15.2 Gauge monitoring

Another panel common to three of the sub-VIs controls how the pressure is monitored during adjustment. The first parameter is a target pressure. Any valve adjustment is always such as to make the pressure approach the Target. The Stability parameter is used together with the Period to ensure that adjustments are not made until the pressure has stabilised following a previous valve adjustment. Values are collected over the specified Period, and a standard deviation calculated. If the standard deviation is lower than the Stability, then the pressure is considered stable and the valve re-adjusted.

The fourth parameter, the pressure Limit, is compared during adjustment to the pressure measured at the associated pressure gauge. If the actual pressure is lower than the Limit, and if the valve has been fully opened, the valve opening process is considered to be complete.

A final refinement to the adjustment process is provided by the Overshoot limit. This is a mechanism whereby excessive pressure can be detected and compensated for immediately, bypassing the normal valve control discussed above. This can be useful on systems where the valve opens particularly suddenly and the 1 K pot might be initially overloaded. The moment the pressure exceeds Target + Overshoot, the valve is immediately shut down to its Initial value.

## 10.16 Replacing the 1 K pot with a Variox Cryostat

If the Variox? check box in the Kelvinox Setup is checked then the software behaves as if the functions of the 1 K pot are performed by a Variox cryostat. In such a system the Variox temperature is controlled by a separate ITC which controls both a heater and a needle valve. The Kelvinox software provides the pumping of the Variox cryostat via valve V4A.

When the Variox temperature is above 5 K, the Variox controller software adjusts the needle valve position every 20 seconds by an amount indicated by Coarse Step (%), to keep the pressure at G3 within ~2mbar of the maximum pressure ( $P_{max}$ ). Below 5 K, G3 is maintained between the limits set by  $P_{high}$  and  $P_{low}$ , adjusting the needle valve every 20 sec by the Fine step(%) control. In order for the software to operate, both the ITC and IGH need to be turned on and connected to the computer. The operating sequences of the fridge automatically launch or stop the Variox controller software as required.

## 10.17 Using the IGH software

The IGH suite of VIs provides a front panel and low level utility VIs for communication with the IGH gas handling instrument and associated IDR<sup>PS</sup> dilution refrigerator power supply. The two instruments share a common serial interface and can be considered as a single unit. Although closely associated with the Kelvinox software described above, the library is in fact a stand-alone unit, and does not use any of the Kelvinox VIs or setup information.

### 10.17.1 The IGH front panel

The IGH Front Panel combines the functions of both the IGH and the IDR<sup>PS</sup> instruments. The gas flow section of the VI closely mimics the real IGH front panel so the function of buttons and LEDs can be deduced from their position on the gas flow diagram.

The VI can be run in parallel with Kelvinox sequences, and will not in itself interfere with their operation. The controls are still active however, and by using them you can affect sequence operations.

**Note** Operations performed at the IGH Front Panel level are **not** checked in any way by the software. You therefore have complete power over the system, including the possibility of losing mixture through careless operation of valves. Always exercise care when using this VI, just as you would when operating the valves directly.

### 10.17.2 The IGH Setup

The setup editor is IGHSetupDialog.vi in IGHSUBS.LLB library.

On-line help is available for this VI and all the sub-VIs. Press CTRL-H and a Help window will appear. Click back on the VI to make it the foreground window again. As you move the mouse pointer, help will be displayed for the nearest control. If the Help window does not seem to work, press either shift key to update the display. Press CTRL-H again to remove the Help window.

## 10.18 The AVS47 Bridge and TS530 Controller

At dilution refrigerator temperatures, the requirement for low sensor excitation powers makes the use of ac measurement techniques necessary. Since the standard ITC temperature controllers use dc excitation, they are unsuitable and are replaced by either combination of the AVS47 ac resistance bridge and TS530 temperature controller, or by an IGH controller with FemtoPower option.

This section describes the AVS47 and TS530 instruments. For more information on the FemtoPower option please see section 10.19.

The resistance bridge is a very low noise device, capable of using excitation voltages down to 3  $\mu$ V. The TS530 is a three-term temperature controller that can only be used in conjunction with the AVS47, although the AVS47 can be used independently of the TS530.

Because of the requirement to minimise radio frequency pickup in the thermometer circuit, a proprietary interface is used for communications between these instruments and the computer. This is known as *Picobus* and it is a serial protocol that does not require the presence of a (potentially noisy) microprocessor in the bridge enclosure. It is only the AVS47 that has the interface; the TS530 is controlled by the AVS over a digital link.

The nature of the Picobus interface means that the normal LabVIEW serial drivers cannot be used, and special routines have been written accordingly. It also means that a separate serial port must be used for these instruments. If you accidentally assign an Isobus port to an AVS47, the port will be incorrectly initialised, and you will not be able to use it for Isobus communications subsequently – even if you try to reinitialise the port. You must exit and restart LabVIEW, and ensure that the first initialisation of the port is the correct one.

Since the AVS47 and the TS530 effectively constitute a single instrument, a single LabVIEW front panel is used for both. The front panel is shown in Figure 6. The recessed panel at the lower left contains the controls specific to the TS530. In the event of a temperature controller not being present, these controls will simply be inoperative<sup>2</sup>, although the front panel appearance will not change.

The main numeric display mimics that of the real AVS47 and can show any one of several values according to the Display control, and as explained in the AVS47 manual. Three smaller displays show the power, voltage and current of the temperature controller heater. These will not in general be accurate values, since the voltage measurement includes any lead resistance in the circuit. LEDs show the Local/Remote status of the instrument, and the status of the 10-times magnifier, used for monitoring changes in resistance. Note that the latter can only be controlled from the real front panel and that when selected, only the Delta R display is valid as all others are erroneously scaled by the same factor 10. This hardware quirk is reproduced in the virtual instrument for consistency.

---

<sup>2</sup>Because the storage for system parameters is all in the AVS47, you will in fact be able to change these parameters as if the instrument were there.

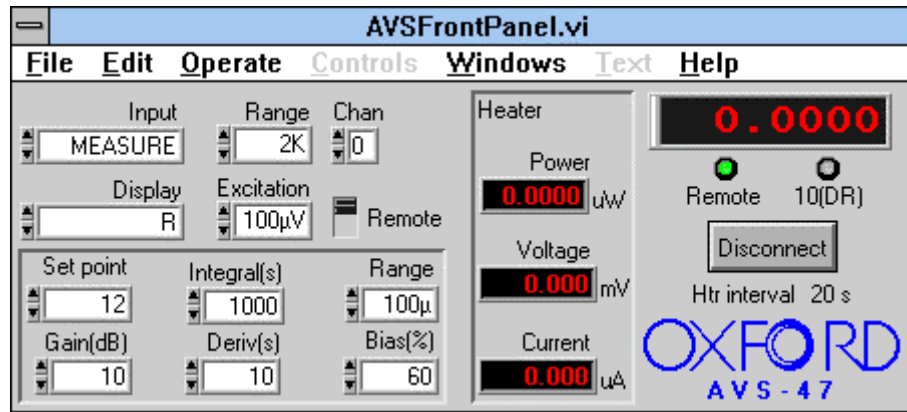

Figure 6 - AVS47/TS530 front panel

When you run the VI, the AVS47 and TS530 are automatically put into Remote mode, and all the VI controls should be enabled. If you switch into Local mode, the controls are greyed out, except for the Local/Remote switch itself. This is to avoid the confusion that might be caused by being able to make changes to the front panel which have no effect on the instrument itself. If you change the instrument directly while it is in local mode, it will be returned to its VI front panel status when you switch it back to Remote. Note that the TS530 Local light is only illuminated if you press the Enter button in the Set Point section of the (real) front panel. The real instrument controls are still functional though, even while the Remote LED is lit.

Most of the controls are restricted to a finite set of possible values. Clicking on the main part of, for example, the Range option will cause a pop-up selector to appear with all the possible ranges displayed, as illustrated in Figure 7. Alternatively, you can use the control arrows on the left hand side of these values to cycle through the possible values. True numeric fields (the Set point) require you to enter a number from the keyboard.

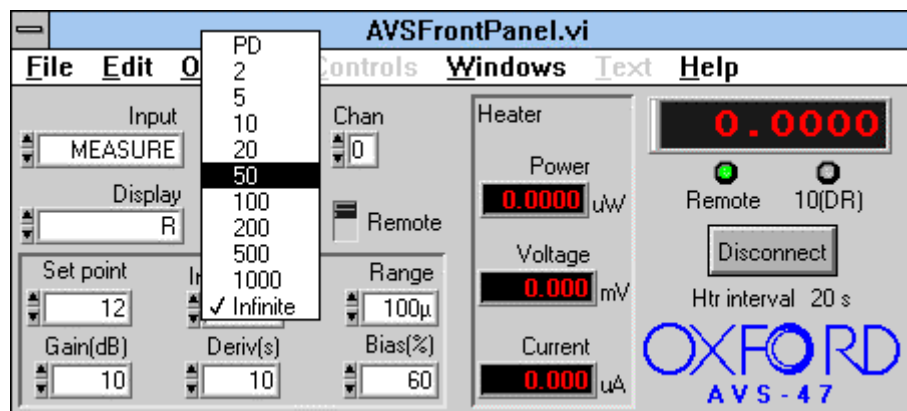

Figure 7 - Using the pop-up selectors

Heater power measurements require the display to be cycled through 530 heater current and 530 heater voltage in order for these values to be read. You can adjust the frequency with which this occurs using the Htr interval parameter. This appears with the run prompt before the VI is started. These readings will be performed even if the TS530 is not present, but can be disabled completely with an interval of zero.

Included in the library is the facility for automatic setting of PIDs. This facility is not available from the Front Panel, and is intended primarily for use from the Kelvinox Front Panel. The VIs can be used independently however and are described here.

The TS530EditPIDs VI is shown in Figure 8. It behaves very similarly to the SetupDialog VIs described in section 4. When loaded, the VI automatically runs, and loads PID data from the AVSPIDS.DAT file in the B-T environment directory. When you have finished editing the data, you can save your changes back to disk by hitting Accept, or discard them by hitting Cancel. As with the setup VIs, you should not edit values while the VI is not running since these changes will be lost. Note the difference in nomenclature between the TS530 and ITC instruments. The TS530 Gain value has a reciprocal relationship with the Proportional value of an ITC, whereas  $T_i$  and  $T_d$  relate directly to integral and differential values respectively.

The data itself consists of an array of resistances along with associated proportional, integral and derivative values (Gain,  $T_i$  and  $T_d$ ). There is a fourth parameter, IDR Range, which is only applicable when using the AVS47 in conjunction with an IDR<sup>PS</sup> in a Kelvinox system. It specifies the mixing chamber power range to be used in that regime. Table values are entered or edited by first selecting the entry number using the array indexer at the top-left of the VI. You can then enter or change all the values as required. When entering new values, be sure to increment the indexer after each entry, or you will simply overwrite your previous entry. These entries are automatically sorted into descending order of resistance when you press Accept.

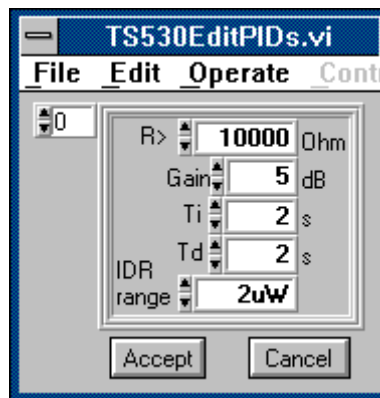
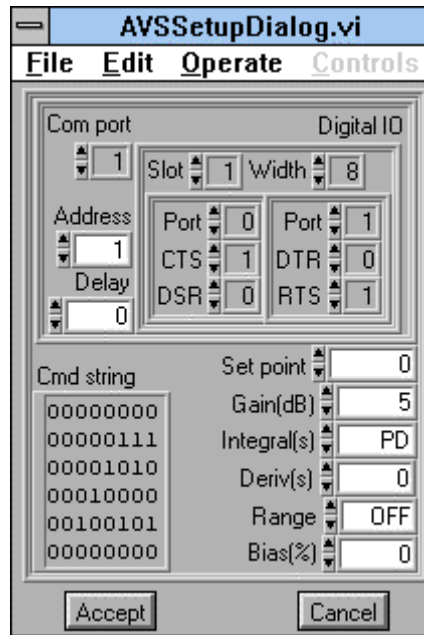

**Figure 8 - PID editor**

When the TS530SetTargResWithPIDs VI is used to set a resistance, as happens when setting a resistance from the Kelvinox Front Panel, the table is searched for the first entry whose resistance is less than the specified value. These values of PID are then sent to the TS530 along with the set point. If an entry is not found, an error message is displayed.

#### **10.18.1.1 The AVS47 Setup**

Load (or run) the VI named AVS47SetupDialog.vi as shown in Figure 9. The VI will auto-run when loaded but will have to be re-run explicitly if it is used a second time.



**Figure 9 - AVS setup dialog**

The address information in the top panel is fairly complicated due to the need to cope with two possible implementations of the interface. On PCs, communication will nearly always be via a com port, in which case you must simply specify the com port number. Macintosh systems will normally use a digital IO card to drive the instrument, and the top right panel specifies this interface. The Slot parameter is the card number, and the width specifies the width of both the input and the output ports. The two sub-panels specify (left to right) the input and output digital ports. The Port Number parameters should be set in accordance with the configuration of your DIO card, and the four line numbers (CTS, DSR, DTR and RTS) specify the DIO line equivalent to the respective com port status line.

The Address and Delay parameters must be set regardless of the implementation. Note that the AVS47 and TS530 (if present) share the same Picobus address and can generally be considered as a single instrument.

It should not be necessary to enter anything other than zero into the delay field, unless you have a very fast machine and are experiencing unreliable communications.

The parameters on the right hand side of the VI are used to store TS530 settings between Front Panel sessions. These values are not part of the command string described below, and cannot be read back from the instrument. They would otherwise be reset to default values on starting the Front Panel. There is little point in editing these directly, since they will automatically be saved at the end of a Front Panel session. Other VIs that use the AVS47 or TS530 should also save modified setups on completion – the Kelvinox Front Panel does this.

You should not need to edit the command string directly: this is used to store the instrument status between runs.

### 10.18.2 The AVS47 Bridge with GPIB Interface

A two-stage GPIB interface is available for the AVS47. It accepts GPIB commands from the computer and translates them into Picobus commands to be forwarded to the AVS. Because the command structure for this interface is completely different than that for the instrument itself, a separate version of the AVS47 library is supplied for such systems. If you did not choose this version at install-time, you must re-install the software. Because the GPIB interface is much simpler to program, there is no associated interface library equivalent to the Picobus library and communications are handled within the instrument library.

The Front Panel is very similar in both appearance and operation to the normal Picobus instrument. The main change is the addition of a Reference control and an associated Set Ref button. These are used to set the reference resistance used for calculation of Delta R values. Enter a resistance value into the Reference control and then press the Set Ref button. If the Display is switched to Delta R, then all values displayed will be relative to this value. Heater values have been moved into a separate panel at the bottom of the VI.

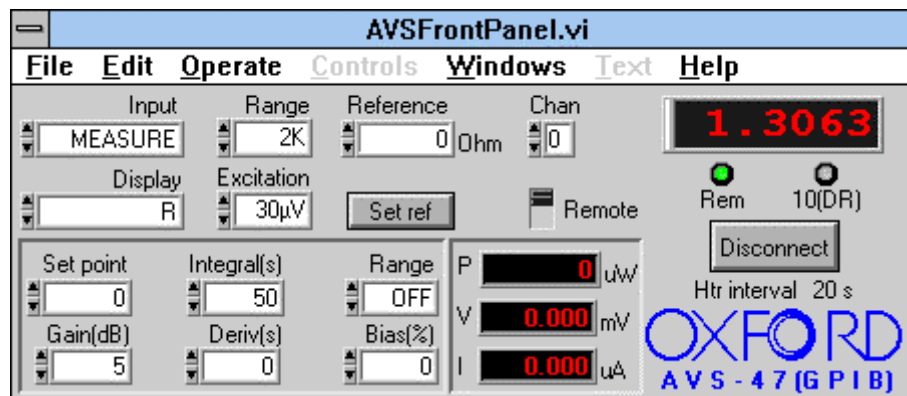

Figure 10 - AVS47 front panel (GPIB version)

#### 10.18.2.1 The AVS47-IB Setup

Load (or run) the VI named AVSSetupDialog.vi as shown in Figure 9. The VI will auto-run when loaded but will have to be re-run explicitly if it is used a second time.

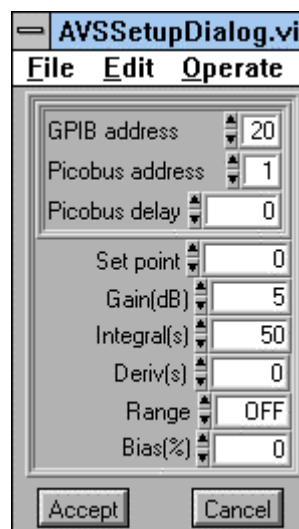

Figure 11 - AVS47-IB setup dialog

The setup information is mostly as described in section 10.18.1.1. There is no Com port or digital IO port information to be provided, simply a GPIB address (which will normally be 20) and a Picobus address (normally 1). The Picobus Delay is now a function only of the cable length between the AVS47-IB and the AVS47 itself.

### 10.18.3 The AVS46 Bridge and TS530 Controller

The AVS46 is an earlier version of the AVS47 and its functions are essentially a subset of the newer instrument. There are only three AVS commands available on the front panel: Range, Chan and Excitation and these behave exactly as described for the AVS47, except for differences in the number of options.

#### 10.18.3.1 The AVS46 Setup

The AVS46 setup is precisely as described for the basic AVS47 in section 10.18.1.1.

### 10.18.4 Sensor Calibration and Ohm to Kelvin Conversion

At dilution refrigerator temperatures, the requirement for low sensor excitation powers makes the use of ac measurement techniques necessary. Since the ITC temperature controllers use dc excitation, they are unsuitable and are replaced by a combination of the AVS47 ac resistance bridge and TS530 temperature controller.

The AVS does not have internal conversion from Ohms to Kelvin and so this is provided by a library of LabView VIs SENSORS.LLB.

#### 10.18.4.1 Setting Up

Use SensorSetupDialog.vi to input the calibration coefficients for the different sensors read by the AVS. Sensor Setup entry  $i$  contains the calibration for the  $i^{\text{th}}$  channel of the AVS. Use CTRL-H to view the help text that is provided for each item of the setup information.

At present the only conversion type available is that for Ruthenium Oxide which has the form:

$$\ln(T) = \sum_i a_i \left( \frac{1}{\ln(R)} \right)^i$$

The coefficients array therefore contains the values of  $a_i$ . There are built-in values for these coefficients for a generic (uncalibrated) sensor. To obtain these built-in values press the button labelled "Set coefficients to generic values".

The setup data is stored in file SENSORS.DAT.

#### 10.18.4.2 Programming Details

Once the sensor setup information has been entered then one simply needs to use the VIs `Sensor R to T` and `Sensor T to R`. For an example of using the VIs see `KelvAVSMonitor.vi` in `kelvutils.llb`.

## 10.19 IGH with FemtoPower Option

The FemtoPower option provides an alternative to using an AVS47 and TS530 for mixing chamber temperature measurement and control. A system with FemtoPower does not require the AVS47 or the TS530, but can optionally include them if desired.

If your IGH instrument supports FemtoPower, this will be indicated by the front panel of the IGH/IDR instrument. In this case, you should check the FemtoPower box in the IGH setup dialog when you first configure the software.

When this box is checked, the IGH instrument is used to monitor and control the mixing chamber temperature instead of an AVS47. When FemtoPower is enabled, a Set T button is present on the Kelvinox front panel which is used to set the mixing chamber set point.

The IGH with FemtoPower instrument uses a PID algorithm for controlling the mixing chamber temperature. A table of PID values for different temperature ranges can be created and edited using IGHFemtoPIDsDialog.vi which is contained in ighsubs.llb

## 11 The KelvinoxAST software

The KelvinoxAST controller can be operated either from the instruments front panel or from a remote computer connected by RS232 or GPIB. Control of the KelvinoxAST via a computer is achieved through a program written in National Instruments LabVIEW and is compatible with LabVIEW versions 3.1.1, 4.x and 5.x. The software allows remote control of the KelvinoxAST with the additional advantage of being able to monitor the dilution refrigerator. Software is also included to edit the parameters used for running the dilution refrigerator set inside the KelvinoxAST controller (shown in Table 10.1 of the KelvinoxAST Controller manual). Altering these parameters however is not recommended.

The KelvinoxAST software can be launched from the Oimenu and offers three options.

### 11.1 Setup Dialog

The first option called setup dialog allows the user to enter the communication parameters the computer requires in order to communicate with the KelvinoxAST controller (namely the COM port, the ISOBUS address and the GPIB address). Once set correctly, this option should no longer be required.

### 11.2 KelvinoxAST Front Panel

When the Front Panel is selected from the Oimenu, a window will appear similar to the one shown in figure 12 below. This panel will immediately update itself and reflect the present status of the KelvinoxAST controller. The user then has the option to run the Circulate, Single Shot, Change Pumps, and Standby sequences as they are required. Parameters for the 1 Kpot, still, IVC sorb, mixing chamber and pumps can be edited. If these parameters are edited, the user has the option of making the current settings permanently saved in the KelvinoxAST Controller by selecting Save Settings (caution should be used with this option). A monitor can also be launched from this Front Panel as described below.

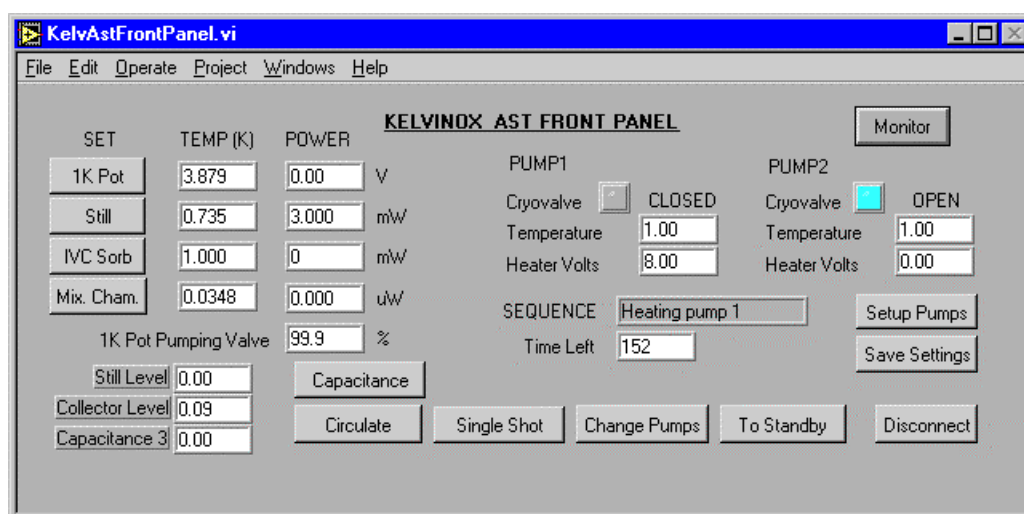

Figure 12 – KelvinoxAST Front Panel dialog box

### 11.3 KelvinoxAST parameter table

The Parameter Table 10.1 in the KelvinoxAST Controller manual is used to control the KelvinoxAST electronics and can be edited by selecting the third option from the Oimenu, namely Edit parameters. Figure 13 shows the appearance of the software window and has a similar arrangement to Table 10.1 (since it refers to exactly the same parameters). A brief description of each parameter is provided in section 10 of the KelvinoxAST Controller manual.

There are six options available; reading and writing to the instrument, reading and writing to file, and reading and writing to an initial circulation file. All these options work to or from the parameter table shown on the computer screen.

It is possible to read the current settings from the KelvinoxAST controller, change the necessary parameters and then send the new values to the instrument. The KelvinoxAST electronics will then operate with the new parameters, however these values at present are not permanently saved. To permanently save these new operating settings inside the KelvinoxAST controller you have to use the save settings option from the KelvinoxAST Front Panel software.

When a parameter table has been downloaded or edited, the user can also save/read these to/from file if required. A particular case of this is for the initial circulation of the KelvinoxAST refrigerator. If modified parameters are required at the beginning of the circulation sequence, then a different parameter table, referred to as the initial circulation parameters, can be loaded into the KelvinoxAST controller, the fridge operated for the appropriate number of cycles, and then the normal operating parameters restored to the controller. These initial parameters are stored in a file on the computer hard drive (filename klvAstc1.ini) and can be viewed or set using the initial circulation options from the Edit parameters window. If the file klvAstc1.ini does not exist, then when the circulation option is chosen from the software Front Panel, the AST controller starts and continues the circulation sequence using the existing parameters held in the AST electronics.

KelvAstParameters.vi

File Edit Operate Project Windows Help

Action:

Parameters

Pump1(P1)	Flag(P1) <input checked="" type="checkbox"/>	Tset(P1) ▲ 45.0 ▼	PB% (P1) ▲ 50.00 ▼	IT (P1) sec ▲ 4 ▼	dV/dt (P1) ▲ 1.00 ▼	dT/dt (P1) ▲ 1.00 ▼	Vmax (P1) ▲ 8.00 ▼
Pump2(P2)	Flag(P2) <input checked="" type="checkbox"/>	Tset(P2) ▲ 45.0 ▼	PB% (P2) ▲ 50.00 ▼	IT (P2) sec ▲ 4 ▼	dV/dt (P2) ▲ 1.00 ▼	dT/dt (P2) ▲ 1.00 ▼	Vmax (P2) ▲ 8.00 ▼
Pump Timings	V-Shut(sec) ▲ 100 ▼	V-Open(sec) ▲ 100 ▼	t-Heat(sec) ▲ 2200 ▼	t-Cool(sec) ▲ 600 ▼	T-Safe ▲ 3.0 ▼	T-Still ▲ 5.000 ▼	
1K Pot Pumping	Flag(1KPP) <input checked="" type="checkbox"/>	TSet(1KPP) ▲ 1.899 ▼	PB% (1KPP) ▲ 50.00 ▼	IT (1KPP) sec ▲ 4 ▼	V-htr1(1KPP) ▲ 3.00 ▼	V-htr2(1KPP) ▲ 3.00 ▼	V-1Khtr(1KPP) ▲ 0.00 ▼
1K Pot Tset	Flag(1KPot Tset) <input checked="" type="checkbox"/>	L-Let ▲ 70 ▼	PB% (1KTset) ▲ 50.00 ▼	IT (1KTset) sec ▲ 12 ▼	TMin ▲ 1.559 ▼	TMax ▲ 1.900 ▼	
Still Power	Flag(Still Power) <input checked="" type="checkbox"/>	P-Normal ▲ 3.00 ▼	Tmax (Still) ▲ 3.000 ▼	L-Max ▲ 90.0 ▼	P-Max ▲ 8.00 ▼		
IVC Sorb Heat	Flag(IVC Sorb Heat) <input checked="" type="checkbox"/>	T-Set ▲ 45.0 ▼	PB%(IVC Sorb Heat) ▲ 100.00 ▼	IT(IVC Sorb Heat) sec ▲ 10 ▼			
Cap Mux etc.	N-Chan ▲ 3 ▼	T-Dwell ▲ 40 ▼	T-Inh ▲ 16 ▼	D-Units ▲ 0 ▼	G-Quant ▲ 2 ▼	N-Quant ▲ 2 ▼	
Mix Ch. T-Ctrl		DV-Ext ▲ 0.00 ▼	PB-Ext % ▲ 100.00 ▼	IT-Ext sec ▲ 9 ▼	PB-Int % ▲ 100.00 ▼	IT-Int sec ▲ 9 ▼	

Figure 13 – KelvinoxAST parameter table

## 11.4 The KelvinoxAST Monitor

To follow the operation of the KelvinoxAST dilution refrigerator, a monitoring program has been provided which shows the temperatures, levels, valves, powers and voltages of various parts of the fridge as a function of time. The data can also be saved to a file if desired for later analysis. If the user wishes to alter which sensors are displayed on each graph, this can be done by selecting the Change Signals option.

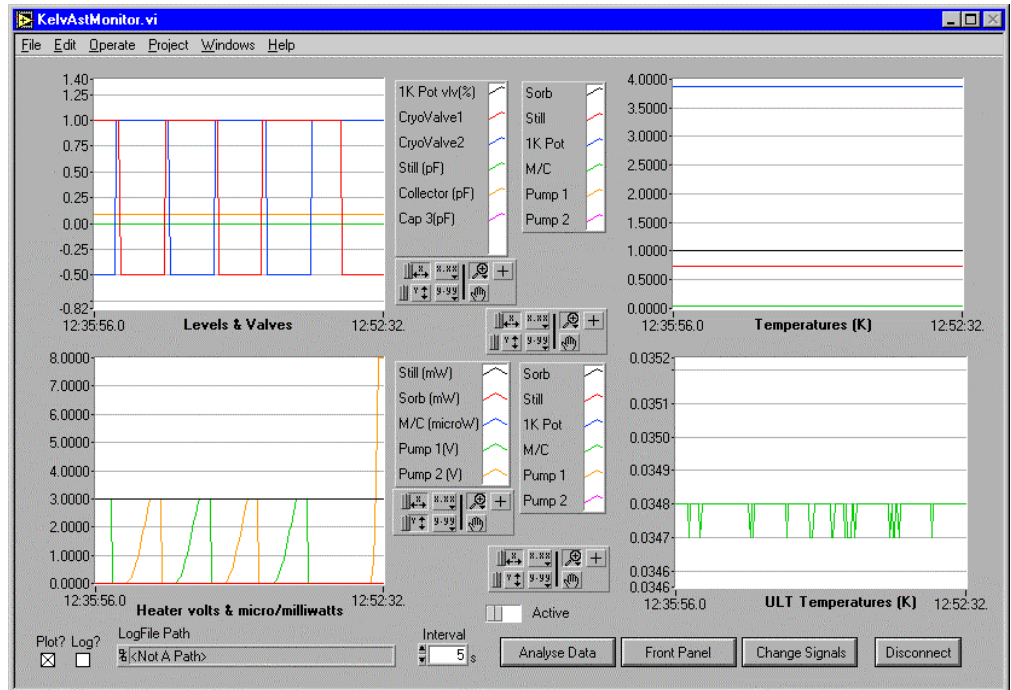

Figure 14 – The KelvinoxAST monitor.